



GUIDE TO
**STANDARDS &
TOLERANCES**
2007

FOREWORD

In 2004-05, the Victorian Building Commission funded research¹ to investigate the number and types of disputes and their causes arising from building contracts. The Building Commission found that in 3.6 per cent of projects there were serious issues that required the intervention of a third party. However, in 78 per cent of projects there were no concerns expressed.

Of particular note, there were problems in around 22 per cent of projects. Industry wide, these problems resulted in millions of dollars worth of costs when dealing with the contractual and construction issues, in rectifying defective work and/or in resolving disputes. The problems generally arose from concerns surrounding issues relating to the quality of building work, concerns about the contract, or scope of building work.

These findings highlight the importance of this *Guide to Standards and Tolerances* publication, which is intended to be used by builders and building owners as a convenient reference to the minimum quality of building work expected. The *Guide* is a valuable tool that will provide guidance for areas of building standards that are not prescribed in legislation, building control and/or policy.

Research suggests that parties to a domestic building contract can reduce the risk of serious disputes by referring to this *Guide* at the time a contract is entered into or later, when there are concerns about the quality of building work.

Overall, the research showed that in the vast majority of cases, there were no concerns with the quality of the building work. Where additional attention is needed in particular projects, this *Guide* will inform and focus the parties on reasonable building outcomes and assist them in gaining a positive building experience.

ACKNOWLEDGEMENT

The *Guide to Standards and Tolerances* was produced in collaboration with the Victorian Building Commission, the Office of Fair Trading NSW, the Tasmanian Government and the ACT Government.

The *Guide* was prepared with the assistance of a panel of representatives from the building industry, professional associations and consumer groups with an interest in building standards and resolving building disputes.

The Building Commission gratefully acknowledges the contribution of all of those who generously gave their time and expertise.

The Building Commission acknowledges that permission to print certain tables and information from the relevant Australian Standards has been granted by SAI Global Ltd. These Australian Standards can be purchased online at www.sai-global.com.

Building Commission

Level 27, Casselden Place
2 Lonsdale Street
Melbourne Victoria 3000
Telephone +61 3 9285 6400
www.buildingcommission.com.au

¹ Building Commission, *Reducing Building Disputes in Victoria*, March 2005

**GUIDE TO
STANDARDS &
TOLERANCES
2007**

DISCLAIMER

This document is a plain language guide to building and quality standards, and tolerances. The Victorian Building Commission believes that all information contained in this document is accurate and reliable. However, the information must not be relied on or regarded as legal advice. No warranty of accuracy or reliability as to the information is given, and no responsibility for loss arising in any way from or in connection with errors or omissions in any information provided (including responsibility to any person by reason of negligence) is accepted by the Building Commission, its employees or agents.

COPYRIGHT

Copyright in the content of this document is owned by the Victorian Building Commission. Except as provided for in the *Copyright Act 1968*, no part may be reproduced without permission.

CONTENTS

ITEM	TOPIC	PAGE
A	Introduction	8
B	Authority of the Guide	9
C	Application of the Guide	10
D	The measurement of time	10
E	The measurement of tolerances	10
F	Inspecting surfaces from a normal viewing position	12
G	Remedial work	13
H	Responsibility to rectify	13
I	Renovations, alterations and extensions	14
J	Recycled materials	14
K	Care of site after completion	14
L	Australian Standards and other referenced material	15
M	Schedule of references used in this Guide	15
1	SITWORKS	16
1.01	Cracking in concrete paving	16
1.02	Finish to external concrete paving	16
2	FOOTINGS, SLABS AND SETTING OUT	17
2.01	Foundation and site drainage – maintenance after occupation	17
2.02	Footings and slabs generally	17
2.03	Setting out the site	17
2.04	External building dimensions	17
2.05	Measuring internal building dimensions	17
2.06	Building dimensions	18
2.07	Finished Floor Levels	18
2.08	Levelness of timber and concrete floors	18
2.09	Dimensions of building elements	18
2.10	Cracks in concrete slabs	18
2.11	Finish to concrete slabs	19
2.12	Repairs to exposed concrete slabs	19

CONTENTS (CONT)

ITEM	TOPIC	PAGE
3	MASONRY	20
3.01	Masonry types	20
3.02	Damage to masonry walls	20
3.03	Articulation in masonry walls	21
3.04	Masonry construction generally	21
3.05	Blending and matching of masonry - repair work	26
3.06	Blending and matching of masonry - new work	26
3.07	Masonry facing	26
3.08	Mortar for masonry	26
3.09	Voids and holes in mortar	26
3.10	Cracked masonry unit	26
3.11	Cleaning, mortar smears and stains	26
3.12	Masonry tolerances	26
3.13	Masonry inside garages and similar spaces and under applied finishes	27
3.14	Vertical alignment of perpend joints	27
3.15	Horizontal alignment of bed joints	27
3.16	Base bed joint and base row of masonry	27
3.17	Masonry that overhangs concrete slabs	27
3.18	Damp proof courses	27
3.19	Raking of joints	27
3.20	Brick sills, sill tiles and shrinkage allowance for timber framing	27
3.21	Sealing of masonry articulation joints	28
4	FRAMING	29
4.01	Verticality or plumbness of stumps or piles	29
4.02	Verticality or plumbness of steel and timber frames and exposed posts	29
4.03	Straightness of steel and timber frame surfaces	29
4.04	Packing under bearers	29
4.05	Timber shrinkage	30
4.06	Treads and risers in timber stairs	30
4.07	Fixing stud walls to concrete slabs	30
4.08	Bottom plates that overhang concrete slabs	31
5	WALL CLADDING	32
5.01	Leaks in wall cladding	32
5.02	Wall cladding	32
6	ROOFING	33
6.01	Flashings and accessories	33
6.02	Leaks in roofing	33
6.03	Roof cladding	33
6.04	Roof tiles	33
6.05	Roof tile pointing	33
6.06	Overhang of roofing (tiles and sheet roofing)	33
6.07	Cutting of roof tiles	34
6.08	Dry valley construction	34
6.09	Undulating tiled roof lines	34
6.10	Alignment of trusses	34
6.11	Verticality or plumbness of trusses	34

CONTENTS (CONT)

ITEM	TOPIC	PAGE
7	PLUMBING	35
7.01	Plumbing general	35
7.02	Positioning of gutters	35
7.03	Water retention in gutters	35
7.04	Joints in gutters	35
7.05	Fixing of gutters and downpipes	35
7.06	Flashings	35
7.07	Water hammer	35
7.08	Pipe penetrations through external walls and inside cupboards	35
7.09	Water discharge from outlets	35
8	WINDOWS AND DOORS	39
8.01	Installation of external windows and doors	39
8.02	Weather-tightness of windows, doors and window and door frames	39
8.03	Door handles, locks and latches	39
8.04	Internal door clearances	39
8.05	Distortion of doors	39
8.06	Sealing of door edges	40
8.07	Operation of windows and doors	40
8.08	Bowed window heads, sills and jambs	40
9	PLASTERING AND RENDERING	41
9.01	Matching and repairing existing rendered surfaces	41
9.02	Cracking and other blemishes in external rendered surfaces on masonry substrate	41
9.03	Repairs to external applied finishes	41
9.04	Articulation or control joints – provision and cracking	41
9.05	Covering articulation or control joints and damp-proof courses	41
9.06	Cracking in external applied finishes used over lightweight substrate	42
9.07	Cracks in internal rendered finishes including hard plaster	42
9.08	Rendered surfaces	42
9.09	Cracking in external mouldings	42
9.10	Verticality or plumbness of internal and external wall surfaces	42
9.11	Straightness of internal and external wall surfaces	42
9.12	Plasterboard sheeting	42
9.13	Defects in other sheeting systems	42
9.14	Level of finish for plasterboard	42
9.15	Cracking in plasterboard, hard plaster and other plaster elements	44
9.16	Cracking in cornices	44
9.17	Cracking at junctions of dissimilar materials	44
9.18	Straightness and alignment of plaster cornices	44
9.19	Peaking or jointing in plasterboard	44
9.20	Nail popping in plasterboard	44

CONTENTS (CONT)

ITEM	TOPIC	PAGE
10	INTERNAL FIXING	45
10.01	Gaps associated with internal fixing	45
10.02	Joints in fixing of internal mouldings	45
10.03	Architrave quirks	45
10.04	Cabinet doors and drawer fronts	45
10.05	Natural materials	45
10.06	Natural stone surfaces	45
10.07	Replacing defective work of natural stone or similar materials	45
10.08	Joints in timber, stone and laminated bench tops	45
10.09	Sealing around benches and items installed in benches	45
11	FLOOR AND WALL TILING	46
11.01	Floor and wall tiling	46
11.02	Floor and wall tiling where the builder supplies the tiles	46
11.03	Floor and wall tiling where the owner supplies the tiles for laying by builder	46
11.04	Floor and wall tiles where the owner supplies and lays the tiles	46
11.05	Cracked, pitted, chipped, scratched, loose or drummy tiles	46
11.06	Grout	47
11.07	Flexible sealants to junctions	47
11.08	Uneven tiling	47
12	PAINTING	48
12.01	Standard of painting	48
12.02	Surface finish of paintwork	48
12.03	Nail and screw fixings	48
12.04	Mechanical damage and natural defects in surfaces	48
12.05	Paint durability	48
13	WET AREAS, DECKS AND BALCONIES	49
13.01	Wet areas	49
13.02	Flashings generally	49
13.03	Shower recess and components	49
13.04	Leaks in water proof decks and balconies	49
13.05	Water proof decks and balconies substrate	49
13.06	Decks and balcony freeboard outside windows and doors	49
13.07	Leaking and ponding of water proof decks and balconies	49
13.08	Calcification and efflorescence associated with decks and balconies	49
14	FLOORS	50
14.01	Timber flooring	50
14.02	Timber flooring generally	50
14.03	Gaps in exposed timber flooring	50
14.04	Joint swelling in timber, plywood and particleboard flooring	50
14.05	Nail popping in timber, plywood and particleboard floors	51
14.06	Squeaking floors	51
14.07	Springy floors	51
14.08	Timber floor levels	51
14.09	Splitting of timber decking	51

CONTENTS (CONT)

ITEM	TOPIC	PAGE
15	ELECTRICAL	52
15.01	Electrical generally	52
16	POOLS AND SPAS	52
16.01	Concrete pools and spas	52
16.02	Premoulded fibre-reinforced plastic pools and spas	52
16.03	Variations from documented dimensions in concrete pools	52
16.04	Variations from documented datum in concrete pools and spas	52
17	RESTUMPING	52
17.01	Restumping	52
17.02	Consequential damage due to restumping	53
17.03	Floor levels after restumping	53
18	GENERAL	53
18.01	Appliances and fittings	53
18.02	Faults and damage to appliances and fittings	53
18.03	Condensation	53
18.04	Glazing	53
18.05	Lyctus borer	53
18.06	Termites and white ants	54
18.07	Termites or white ant damage	54
18.08	Water leaks	54
18.09	Cleaning	54
18.10	Maintenance	54
	APPENDIX	55
	Relevant legislation	55
	HISTORY OF EDITIONS	56



INTRODUCTION

The purpose of this *Guide to Standards and Tolerances* is to set out in a single document some of the regulated standards and a reasonable position on standards that can be applied to non-regulated aspects of domestic building construction. The scope of the *Guide* is based on experience gained in facilitating the resolution of many domestic building disputes. It covers issues that are often of concern to building owners and builders.

What is a reasonable standard of construction and workmanship in a domestic building project? The majority of domestic building disputes arise because of differing answers to this question.

Generally, a builder and a building owner, parties to a building contract, can agree to apply the standards they consider appropriate to a building project. Preferably, the agreed scope of work and standards of work are comprehensively detailed in the contract documents, but often they are not.

While the parties can agree on applicable standards, they cannot apply standards lower than those regulated by Government. The minimum standards for some aspects of construction are regulated, but many aspects are not.

Where contract documents are not comprehensive or clear and especially if there are no regulated standards, disputes may arise.

This document may be used as a guide to determine whether or not an item is defective.

AUTHORITY OF THE GUIDE

Each State and Territory has legislated to empower the making of building standards and to control the key elements of a domestic building contract. (Refer to Appendix A for a schedule of the principal legislation.)

Regulated building standards are in the main described in the *Building Code of Australia*, which is adopted into law by regulation. In a hierarchy, the regulatory framework for building standards starts with the relevant Act of Parliament or Legislative Assembly, passes to regulations made under that Act, then to the *Building Code of Australia*, to the Australian Standards and other documents referenced in the *Building Code of Australia*.

The *Guide to Standards and Tolerances* is only a guide and an advisory document. It is not a regulated standard and is not part of this hierarchy.

Each State and Territory has an Act to regulate the contents of a domestic building contract and the responsibilities of parties. These Acts also require compliance with regulated building standards and require buildings and their materials to be fit for their intended purposes.

This *Guide* can be used to determine whether or not an item is defective only where this cannot be done by reference to the contract documents, the relevant Australian Standards, the *Building Code of Australia* or the relevant regulations. Where there is any contradiction or difference between the *Guide* and an Act, a regulation, the *Building Code of Australia* or a building contract, all of these take precedence over the *Guide*. The *Guide* does not replace the requirements of these other documents.

Some Australian Standards are referred to whole or in part in the *Building Code of Australia*. The referenced parts of these Australian Standards take precedence over this *Guide*.

Fittings, equipment and some materials used in buildings are often supported by a manufacturer's installation instructions. The manufacturer's installation instructions take precedence over this *Guide*.



APPLICATION OF THE GUIDE

The *Guide to Standards and Tolerances* is intended to inform parties to domestic building contracts and those involved in disputes arising from domestic building contracts. It should be noted that builders, subsequent owners and those purchasing from owner-builders or developers can also use this *Guide* to resolve possible disputes, irrespective of whether or not they were a party to the original building contract.

This edition of the *Guide* is valid from 1 January 2007 and is applicable to domestic building contracts entered into from that date.

THE MEASUREMENT OF TIME

Any time period mentioned in the *Guide* is to be taken to start at the date of completion of the building work as it is legislated in the State or Territory where the building work is located.

Generally, the date of completion is the day when the work carried out under the contract is completed in accordance with the terms of that contract, or the day the building owner is given the statutory permit or certificate that authorises the occupation of the building. A more precise definition should be given in the contract associated with the building work.

THE MEASUREMENT OF TOLERANCES

The tolerances in this *Guide* apply up to and including the length over which each tolerance is stated to apply. It is not intended that tolerances will be interpolated or proportioned to the actual length of building element measured. For example, where the *Guide* specifies a 4 mm maximum deviation measured over a 2 m length of wall surface, the *Guide* means that the same 4 mm deviation is to be applied over a 1 m wall surface or a 500 mm wall surface. The tolerance cannot be interpolated to mean a 2 mm deviation over a 1 m wall surface or 1 mm deviation over a 500 mm wall surface. Similarly, deviations over longer wall surfaces would be defects if the deviation exceeded 4 mm within any 2 m length of that surface.

Horizontal, vertical and diagonal surface tolerances are to be interpreted in the same way.

Horizontal surfaces

Deviations from a horizontal surface are to be measured from a datum nominated in the contract documents or inferred, if none is nominated. Where there is a nominated or inferred datum, the maximum deviation from that datum will not exceed the deviation stated in the *Guide*. Where no datum is nominated and a datum cannot be inferred, a datum level will be taken to be at the highest or lowest points in the building element, room or area being measured. Refer to diagram E (i), (ii) and (iii).

Vertical surfaces

Deviations of a vertical surface from a true vertical plane are to be measured from a plumb line through a plan position or reference point nominated in the contract documents or inferred if none is nominated. The maximum deviation of a vertical surface from that plumb line will not exceed the deviation stated in the *Guide*. Refer to diagram E (iv), (v) and (vi).

Where diagrams are provided for the clarification of details, the diagram shows only detail relevant to the issue and is not intended to be used as general details for construction.

THE MEASUREMENT OF TOLERANCES (CONT)

DIAGRAM E
MEASUREMENT OF HORIZONTAL AND VERTICAL TOLERANCES

Horizontal surfaces

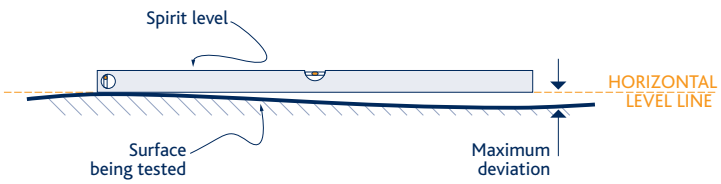

i) Measurement of deviation from horizontal / level

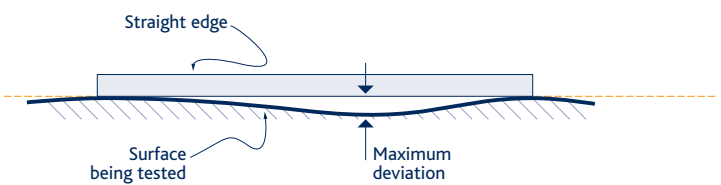

ii) Measurement of bow

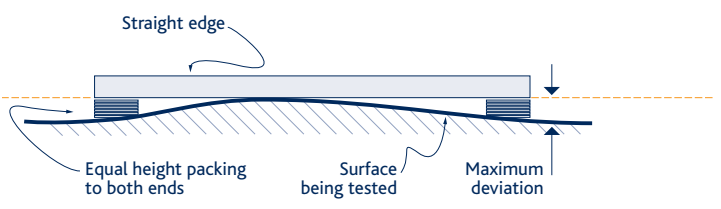

iii) Measurement of bow

Vertical surfaces

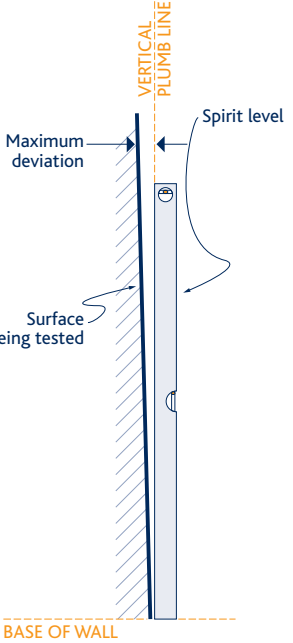

iv) Measurement of deviation from vertical / plumb

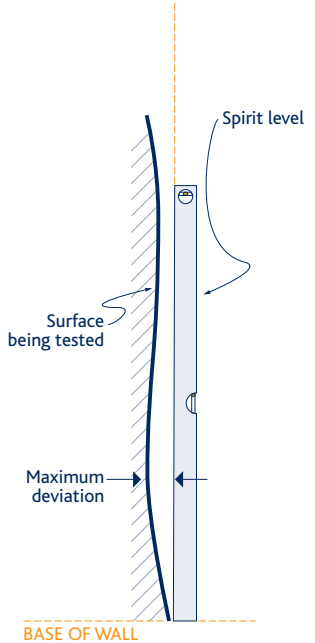

v) Measurement of bow to be carried out as per diagram (ii)+(iii)

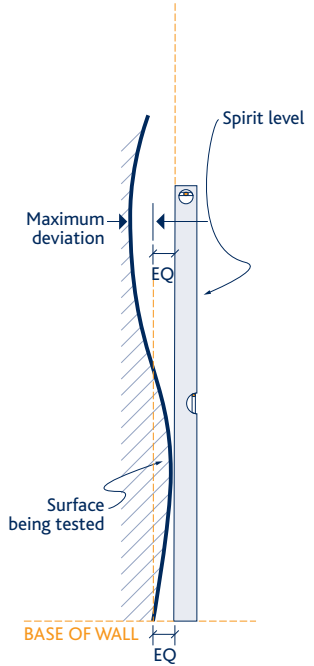

vi) Measurement of bow to be carried out as per diagram (ii)+(iii)

INSPECTING SURFACES FROM A NORMAL VIEWING POSITION

Generally, variations in the surface colour, texture and finish of walls, ceilings, floors and roofs, and variations in glass and similar transparent materials are to be viewed where possible from a normal viewing position. A normal viewing position is looking at a distance of 1.5 m or greater (600 mm for appliances and fixtures) with the surface or material being illuminated by "non-critical light". "Non-critical light"² means the light that strikes the surface is diffused and is not glancing or parallel to that surface.

Slight variations in the colour and finish of materials do not always constitute a defect.

DIAGRAM F
NORMAL VIEWING POSITIONS

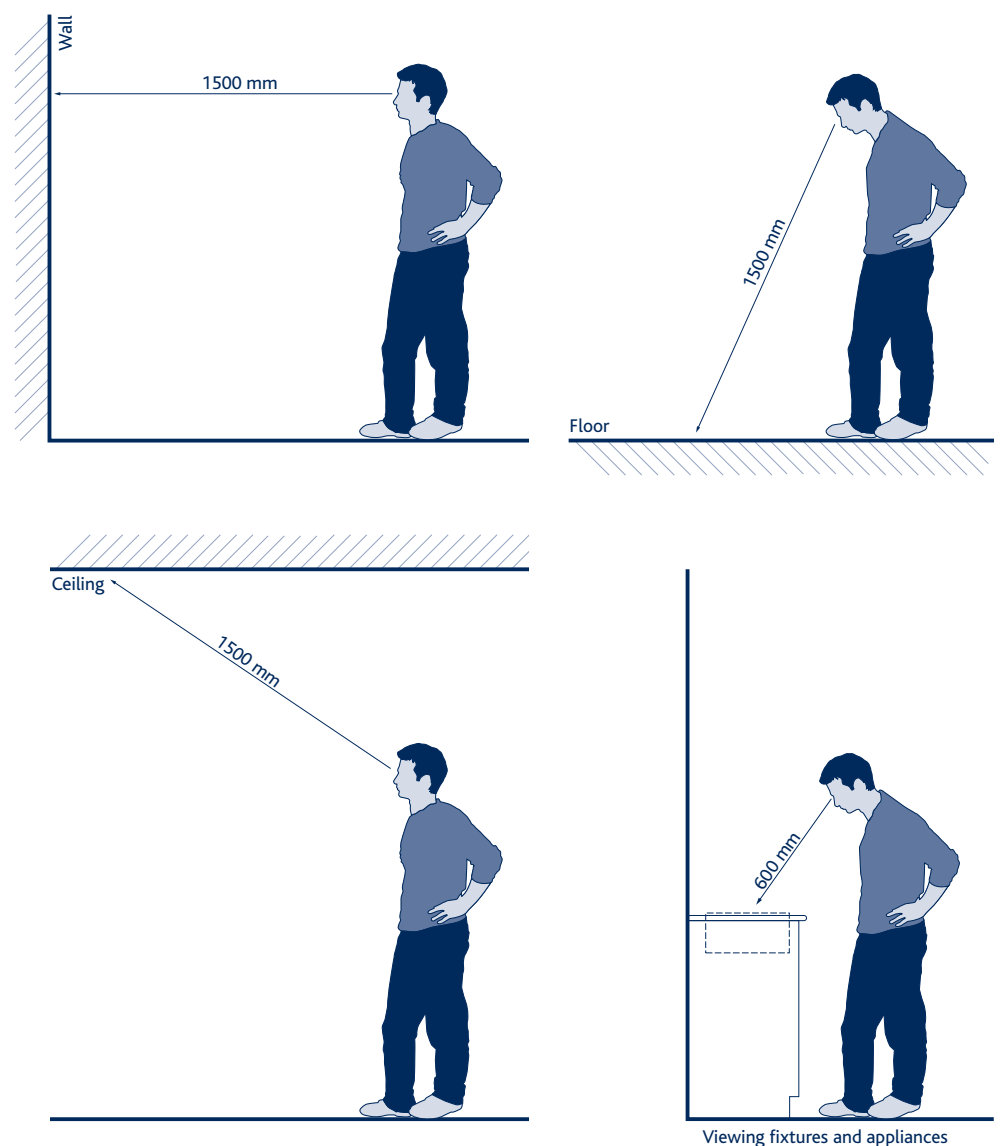

² Non-critical light is defined in s.6.7(4) Australian Standard AS/NZS 2589.1: Gypsum linings in residential and light commercial construction – Application and finishing, Part 1:Gypsum plasterboard. Refer also to CSIRO Division of Building Research Report No TR 90/1: *Illumination and Decoration of Flat Surfaces*.



REMEDIAL WORK

It is envisaged that work to rectify defects will be carried out to match as closely as practical the surrounding materials, finishes, levels and other characteristics of the area to be rectified. In some circumstances, exact matching may not be possible.

Structural rectification work may need to be designed by a structural engineer and inspected or certified by a building surveyor or certifier.

Some remedial work may need to be agreed by way of a contract variation and variation to a building permit or construction certificate before it is carried out.

RESPONSIBILITY TO RECTIFY

The standards and tolerances in this *Guide* only apply to building work that is the responsibility of a builder under a domestic building contract. A builder is not liable to rectify building design and defects that do not arise from the builder's or the builder's subcontractor's work and design. Builders do not have to rectify damage caused by the owner's actions or those of other people engaged by the owner. Builders will be liable to repair damage caused to property in the course of completing their building work. For example:

- » A builder **will not** have to repaint a poorly painted wall that was painted by the building owner.
- » A builder **will not** have to repair a distorted gutter when the damage was caused by an owner placing a ladder against the gutter.
- » A builder **will not** have to repair a storm water drain that was properly constructed and later blocked by tree roots.
- » A builder **will** have to replace untreated pine in an external deck that was installed by the builder instead of the durable timber required for this structure.
- » A builder **will** have to repair an existing window in a house that the builder accidentally damaged when constructing another part of the house.



RENOVATIONS, ALTERATIONS AND EXTENSIONS

The standards and tolerances in this *Guide* only apply to the work covered in the relevant domestic building contract.

It is recommended that before starting new work, the builder informs the owner of any potential circumstances and conditions of the existing building that may have a detrimental effect on the standard of the new work. For example, the builder should advise the owner if the substructure of an existing building may be deteriorated in a way which could affect the new work.

The builder and owner should agree as part of their domestic building contract, or as a written variation to that contract, on the extent of any necessary replacement works that may be required to be carried out to the existing building before commencing that work.



RECYCLED MATERIALS

The standards and tolerances in this *Guide* may not apply to construction with second-hand or recycled materials and products.



CARE OF SITE AFTER COMPLETION

It is recommended that owners consider the information on site drainage and foundation maintenance in CSIRO document BTF18, *Foundation Maintenance and Footing Performance: A Homeowner's Guide*. This and other similar documents discuss soil movement and its effects on buildings, including the effects of tree planting and site drainage. Owners can reduce the risk of cracking and damage to building structures by adopting the landscape care suggestions in that document. Refer also to clause 2.01 of this *Guide* – Foundation and site drainage – maintenance after occupation.

AUSTRALIAN STANDARDS AND OTHER REFERENCED MATERIAL

Where this *Guide* refers to Australian Standards, CSIRO Division of Building Research Reports and other similar material, the edition referred to is the one that was current at the time the *Guide* was published and applicable to the relevant building contract. In many cases this will be a document referred to in the *Building Code of Australia* that was current at that time.

SCHEDULE OF REFERENCES USED IN THIS GUIDE

2006	<i>Building Code of Australia</i>
AS 1684 – 2006	Residential timber-framed construction
AS 1860 – 1998	Installation of particleboard flooring
AS 2047 – 1999	Windows in buildings – Selection and installation
AS 2783 – 1992	Use of reinforced concrete for small swimming pools
AS 2870 – 1996	Residential slabs and footings – Construction
AS 3598.1 – 1991	Ceramic tiles – Guide to the installation of ceramic tiles
AS 3598.2 – 1992	Ceramic tiles – Guide to the selection of a ceramic tiling system
AS 3700 – 2001	Masonry structures
AS 3727 – 1993	Guide to residential pavements
AS/NZS 1839 – 1994	Swimming pools – Premoulded fibre-reinforced plastics – Installation
AS/NZS 2311 – 2000	Guide to the painting of buildings
AS/NZS 2589.1 – 1997	Gypsum linings in residential and light commercial construction – Application and finishing, Part 1:Gypsum plasterboard 1997
AS/NZS 3500.3 – 2003	Plumbing and drainage - Stormwater drainage
CSIRO document BTF18 – 2003	Foundation Maintenance and Footing Performance: A Homeowner’s Guide
CSIRO TR 90/1 Report No. L8 – 1992	CSIRO Division of Building Research Report No TR 90/1: Illumination and Decoration of Flat Surfaces – 5th Edition (Revised)



SITWORKS

1.01 Cracking in concrete paving

Cracking in concrete is common and is not always attributable to unsatisfactory workmanship. Common causes of cracking include shrinkage stress, stress due to trees, commercial or heavy vehicle traffic, soil movement due to changes in the moisture content due to garden watering or drainage problems.

Cracking not attributable to the workmanship of the builder (e.g. trees planted too close to paving, commercial or heavy duty vehicle traffic, use of sprinkler system, etc.) is not a defect.

Cracking in concrete verandahs, garages, carports, paving, patios, driveways etc. where the builder did not make allowances for shrinkage or general movement of the concrete (e.g. slip joints where required around penetrations such as verandah posts, pipes etc), shall be assessed in accordance with table 1.01 and is defective where the limits in that table are exceeded.

TABLE 1.01
CRACKS IN CONCRETE PAVING

Condition	Measure	Limit
Cracking	Crack width	1.5 mm
Subsidence	Heave or slump under 2 m long straight edge (See Note 2 below)	15 mm
Stepping	Relative surface level of adjacent paving elements within the expanse of the main pavement	5 mm

Based on: AS 3727 – Guide to residential pavements: Table:1 Performance criteria

Notes to table 1.01

1. The straight edge is centred over the defect and supported at its ends by equal height spacers. The heave or slump is then measured relative to this straight edge.
2. The stepping criteria apply only to steps within the surface of the main pavement. It shall not be applied where the main pavement abuts other structures such as edging, drainage pits, service pits, minor pavements (such as a pathway adjacent to a driveway) and pavements constructed with materials of a different type.

1.02 Finish to external concrete paving

Concrete paving finish is defective if it is not consistent in colour, texture and general appearance. Minor variations in finish may occur and may not be considered to be defective.

FOOTINGS, SLABS AND SETTING OUT

2.01 Foundation and site drainage – maintenance after occupation

The builder is not responsible for foundation movements caused by activities that were not documented at the time of entering into the contract or as variation to that contract, or that are undertaken by the owner. These include paving, landscaping, planting trees and drainage works after the site is handed over to the owner.

The builder is not responsible for foundation movements caused by the owner's failure to maintain drainage systems after the site is handed over to the owner.

Refer to the CSIRO publication *Guide to Home Owners on Foundation Maintenance and Footing Performance*.

2.02 Footings and slabs generally

Slabs and footings are defective if they fail because they are not designed and constructed in accordance with the *Building Code of Australia* or *AS 2870 – Residential slabs and footings – Construction*.

Slab and footing failures are defects when they are caused by foundation movements that are the result of localised drying and wetting caused by such factors as the effects of trees, excessive wetting or lack of site drainage when these factors were present during construction.

2.03 Setting out the site

A building set out is defective where the set out has failed to comply with the requirements of the approved drawings, the allotment Certificate of Title, planning or development approval, relevant planning overlays and schemes, and building regulations.

The set out for a building is defective if the building is more than $L/200$ from its correct position or 5 mm, whichever is the greater, where L is the correct setback or distance from the boundary to the exterior face of the building.

2.04 External building dimensions

Departures from documented external dimensions of buildings are defects if they exceed $L/200$ where L is the documented overall length of wall, or 5 mm, whichever is the greater.

2.05 Measuring internal building dimensions

Unless shown otherwise, dimensions shown on drawings for internal walls always refer to the structure's dimensions. Structure means masonry and timber framing and does not include finishes such as plasterboard, render and skirtings. The internal room sizes will be different when thicknesses of internal finish materials are taken into account.

Unless shown otherwise, clear room height dimensions shall be provided in accordance with the requirements of the *Building Code of Australia*.

FOOTINGS, SLABS AND SETTING OUT (CONT)

2.06 Building dimensions

Departures from the documented set out for service rooms such as bathrooms, toilets, laundries, kitchens etc. are defects if they exceed $L/200$ or 5 mm, whichever is the greater, where L is the documented dimension.

Departures from the documented set out for habitable rooms and areas, such as bedrooms, dining rooms, lounge and living rooms, family rooms, studies, halls, entries and stairways are defects if they exceed $L/100$ or 5 mm, whichever is the greater, where L is the documented dimension.

Departures from documented set out for external elements such as garages, car ports, verandahs, decks, patios, etc. are defects if they exceed $L/100$ or 5 mm, whichever is the greater, where L is the documented dimension. Masonry work shall comply with table 3.04.

The set out is defective where a specific fixture or feature is required to be accommodated, and such documented dimensions to accommodate that fixture or feature are not provided.

2.07 Finished Floor Levels

Finished Floor Levels (FFL) or Reduced Levels (RL) are defective where:

- » they do not comply with planning and building requirements, for example minimum levels in flood prone areas; and
- » they depart from the documented RL or FFL by more than 40 mm; or
- » floors that are documented to be on the same plane but are constructed on different planes; or
- » the building work is an extension or addition and new floor levels do not match the existing building floor levels. Also refer to clause H of this *Guide*.

2.08 Levelness of timber and concrete floors

Except where documented otherwise, new floors are defective if within the first 24 months they differ in level by more than 10 mm in any room or area, or more than 4 mm in any 2 m length. The overall deviation of floor level to entire building footprint shall not exceed 20 mm. Refer to clause I of this *Guide* where the new floor is to join an existing floor.

2.09 Dimensions of building elements

Deviations from the documented height or cross-sectional dimension of building elements such as beams and posts are defective if they exceed $L/200$ where L is the documented dimension or 5 mm, whichever is the greater.

2.10 Cracks in concrete slabs

Refer to table 2.10 for descriptions of categories of cracks.

Category 3 and 4 cracks to slabs are defects.

Category 1 and 2 cracks to slabs are to be monitored for a period of 12 months.

At the end of the monitoring period, cracks rated at greater than category 2, are defects.

FOOTINGS, SLABS AND SETTING OUT (CONT)

TABLE 2.10
CLASSIFICATION OF DAMAGE TO CONCRETE FLOORS

Description of typical damage	Approx. crack width limit in floor	Change in offset from 3 m straight edge placed over defect (See Note 4)	Crack category
Hairline cracks, insignificant movement of slab from level	< 0.3 mm	< 8 mm	0
Fine but noticeable cracks. Slab reasonably level	< 1.0 mm	< 10 mm	1
Distinct cracks. Slab noticeably curved or changed in level	< 2.0 mm	< 15 mm	2
Wide cracks. Obvious curvature or change in level	2 mm to 4 mm	15 mm to 25 mm	3
Gaps in slab. Disturbing curvature or change in level	4 mm to 10 mm	> 25 mm	4

Based on: AS 2870 Residential slabs and footings – Construction Table C2: Classification of damage with reference to concrete floors

Notes to tables 2.10 and 3.02

1. Crack width is the main factor by which damage to floors and walls is categorised. The width may be supplemented by other factors, including serviceability, in assessing category of damage.
2. In assessing the degree of damage, account shall be taken of the location in the building or structure where it occurs and also of the function of the building or structure. In smaller spaces with dimensions less than 3 m, the allowed offset may be used proportionally.
3. Where applicable, account shall be taken of the past history of damage in order to assess whether it is stable or likely to increase.
4. The straight edge is placed over the defect, and supported at its ends by equal height spacers. The change in offset is then measured relative to this straight edge.

2.11 Finish to concrete slabs

The finish to a concrete slab is defective if it is not suitable for the documented applied finishes such as tiles, polished concrete, carpet or sheet flooring, including set downs where required.

2.12 Repairs to exposed concrete slabs

Repairs, where failure has been due to cracking and/or movement, may involve the removal of the affected area. The repair is defective if it does not, as closely as practicable, match the existing work in appearance, colour and texture. Minor variations in finish may not be considered to be defective.

MASONRY

3.01 Masonry types

This section includes tolerances for the following generally-used types of masonry, including:

- » Clay and concrete brick construction
- » Clay and concrete brick veneer construction
- » Concrete block construction.

The tolerances for the above may not always be appropriate for some types of masonry construction, such as pre-fabricated masonry panels, aerated concrete blocks, irregular cut stone, rustic finish masonry with irregular edges and appearance, etc. In these cases, parties must obtain the manufacturer's advice.

3.02 Damage to masonry walls

Refer to table 3.02 for descriptions of categories of damage.

Category 3 or greater damage to walls is a defect and requires investigation, stabilisation, monitoring and rectification work, which may include breaking out and replacing sections of the wall.

Category 2 cracks to walls are to be monitored for a period of 12 months. At the end of the monitoring period, a crack rated at category 2 or above is a defect and requires rectification. Category 2 damage is a defect and requires minor repair work such as repointing.

TABLE 3.02
DAMAGE TO WALLS CAUSED BY MOVEMENT OF SLABS AND
FOOTINGS AND OTHER CAUSES

Description of typical damage and required repair	Crack width limit	Crack category
Hairline cracks	< 0.1 mm	0
Fine cracks that do not need repair	< 1 mm	1
Cracks noticeable but easily filled. Doors and windows stick slightly	< 5 mm	2
Cracks can be repaired and possibly a small amount of wall will need to be replaced. Doors and windows stick. Service pipes can fracture. Weather tightness often impaired	5 mm to 15 mm (or a number of cracks 3 mm or more in one group)	3
Extensive repair work involving breaking-out and replacing sections but also depends of walls, especially over doors and windows. Window and doorframes distort. Walls lean or bulge noticeably, some loss of bearing in beams. Service pipes disrupted	15 mm to 25 mm but also depends on number of cracks	4

Based on: AS 2870 Residential slabs and footings – Construction Table C1: Classification of damage with reference to walls

Refer also to notes to table 2.10

MASONRY (CONT)

3.03 Articulation in masonry walls

Masonry work is defective if articulation and movement control joints have not been provided as required.

3.04 Masonry construction generally

Masonry work is defective if it exceeds the tolerances set out in table 3.04.

TABLE 3.04
TOLERANCES IN MASONRY CONSTRUCTION

Item	Column 1 Structural Tolerance	Column 2 Non-Structural Framework Tolerance	Reference
A Horizontal positions of any masonry element documented or shown in plan at its base or at each storey level	15 mm	15 mm	Diagram 3.04 (A) Do not exceed set out tolerances in clause 2.03
B Relative displacement between load-bearing walls in adjacent stories intended to be in vertical alignment	10 mm	10 mm	Diagram 3.04 (B)
C Maximum deviation from plumb within a storey from a vertical line through the base of the member	The lesser of 10 mm per 3 m of height or 0.05 times the thickness of the leaf	10 mm	Diagram 3.04 (C)
D Maximum deviation from plumb in total height of the building (from the base)	25 mm	25 mm	Diagram 3.04 (D)
E Maximum horizontal or vertical deviation of a surface from a plane surface (bow) in any 2 m length	5 mm	3 mm	Diagram E(i) E(iv) page 11
F Deviation (step) of any exposed brick surface from any adjacent exposed brick surface. The bow provision of item (E) above also applies	Not applicable	2 mm	Diagram 3.04 (D)

Based on: AS 3700 – Masonry structures – Table 11.1: Tolerances in masonry construction

MASONRY (CONT)

TABLE 3.04 (CONT)
TOLERANCES IN MASONRY CONSTRUCTION

Item	Column 1 Structural Tolerance	Column 2 Non-Structural Framework Tolerance	Reference
G Deviation of bed joint from horizontal, or from the level documented or shown in elevation	10 mm in any 10 m length, 15 mm in total	10 mm in any 10 m length, 15 mm in total	Diagram 3.04 (G)
H Deviation from documented thickness of bed joint	3 mm	3 mm	Diagram 3.04 (H)
I Minimum perpend thickness	5 mm	5 mm	Diagram 3.04 (I,J)
J Deviation from documented thickness of perpend	10 mm maximum	5 mm	Diagram 3.04 (I,J)
K Maximum difference in perpend thickness in any wall	No limit	8 mm	Diagram 3.04 (I,J)
L Deviation from documented width of cavity minimum width as required by the BCA	15 mm	15 mm	Diagram 3.04 (L)

Based on: AS 3700 – Masonry structures – Table 11.1: Tolerances in masonry construction

Notes to table 3.04

1. Items H, I, J and K are not applicable to thin-bed mortar joints.
2. Items I and J tolerances are not applicable when perpend joints are not filled with mortar as is the case with some horizontally cored masonry that is not required to resist horizontal bending.
3. Items E, F and I only apply to the true, fair or finish face of single skin masonry.

Refer to AS 3700 – Masonry structures for detailed information.

MASONRY (CONT)

DIAGRAMS FOR TABLE 3.04 TOLERANCES IN MASONRY CONSTRUCTION

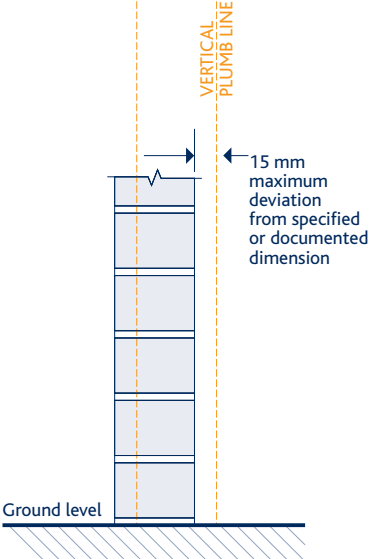

A)

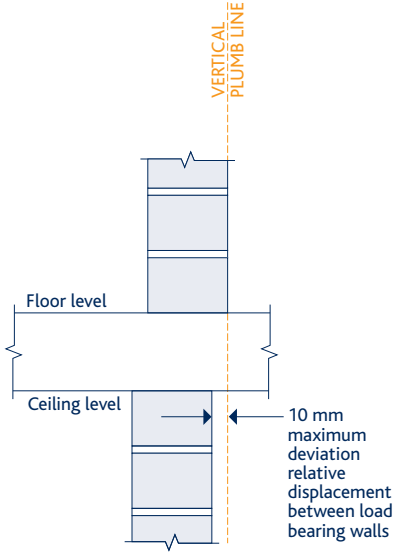

B)

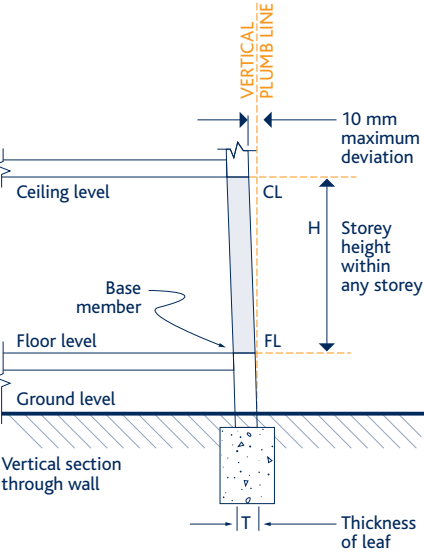

Formula:
Maximum Deviation from plumb within any storey
Structural lesser of $\pm \left(\frac{10H}{3}\right)$ or $\pm 0.05T$
H measured in m
T measured in mm
For example if a storey height,
H= 4000 mm and leaf thickness,
T= 190 mm. Tolerance is the lesser of
 $10 \times 4.0 \div 3 = 13.3$ mm or $0.05 \times 190 = 9.5$ mm
ie. 9.5 mm

C)

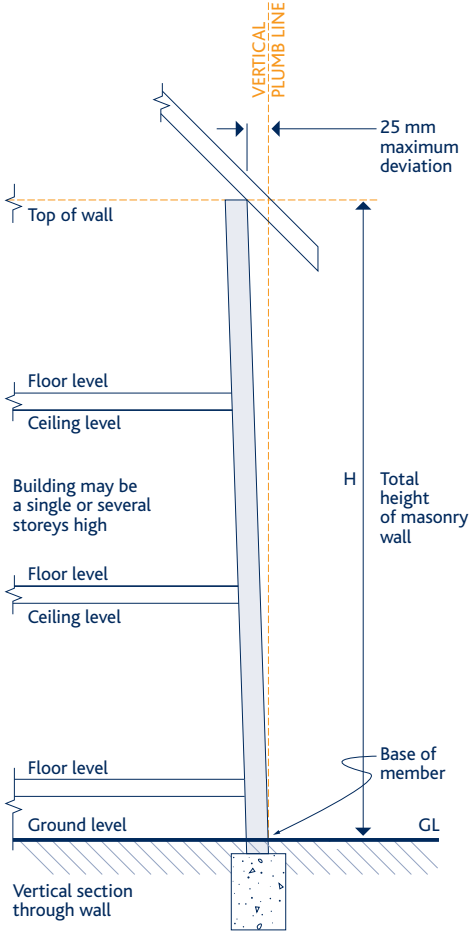

D)

MASONRY (CONT)

DIAGRAMS FOR TABLE 3.04 (CONT)
TOLERANCES IN MASONRY CONSTRUCTION

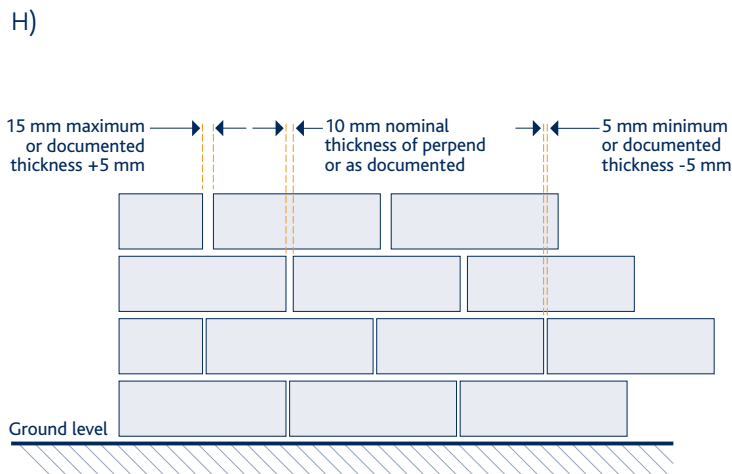
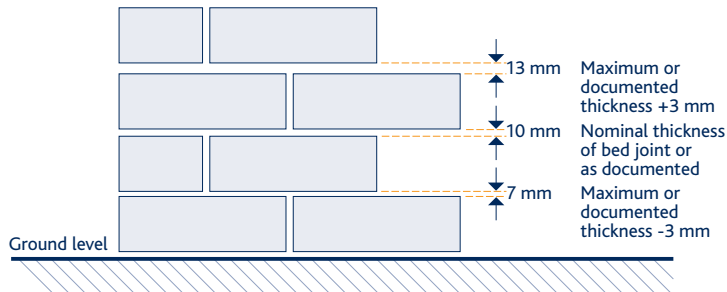
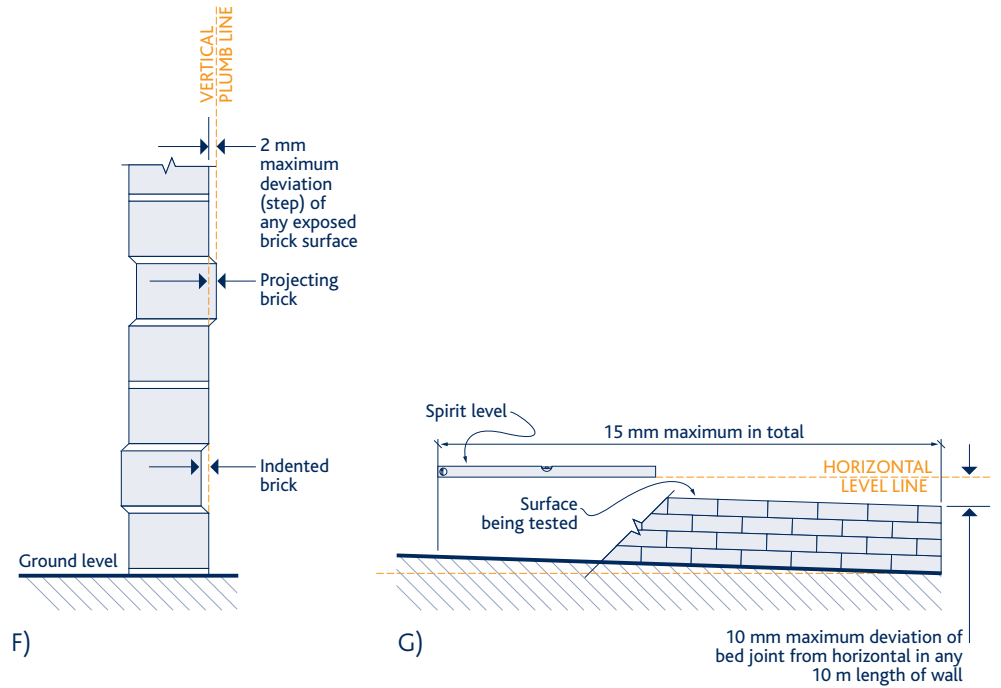

I+J) Note: Table 3.04 (K) provides that maximum difference in width of perpend in any wall must not exceed 8 mm.

MASONRY (CONT)

DIAGRAMS FOR TABLE 3.04 (CONT) TOLERANCES IN MASONRY CONSTRUCTION

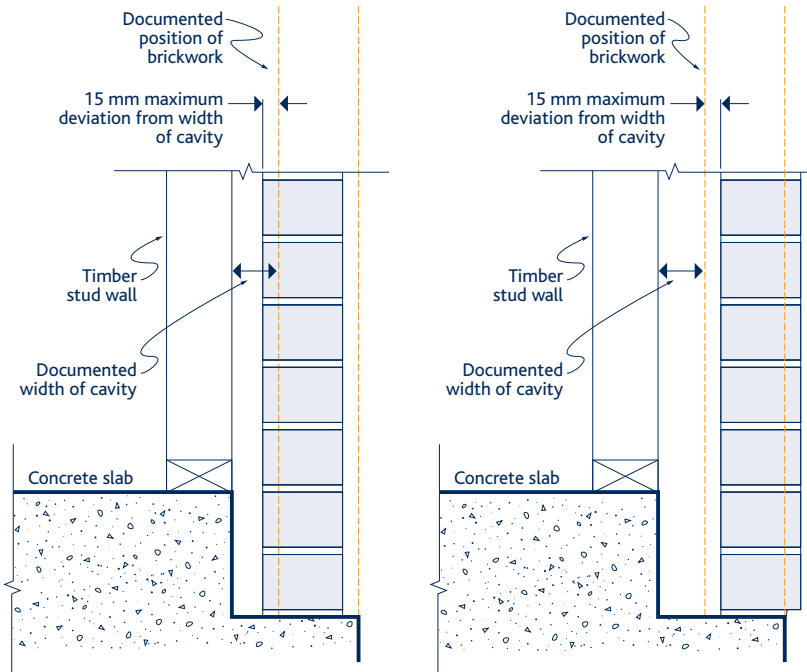

L) Note: Refer BCA for minimum cavity width

MASONRY (CONT)

3.05 Blending and matching of masonry – repair work

If matching masonry in alteration and repair work is not reasonably possible, builders should use a practical approach and where possible a physical joint, a door or window, downpipes or other similar separating materials be incorporated to “break” the visual impact.

Mortar repairs should be carried out to match existing mortar as closely as practicable. A perfect colour match may not be possible and differences may diminish over time.

Some variation of masonry features such as colour, texture and pattern are to be expected between batches.

3.06 Blending and matching of masonry – new work

To avoid inconsistency in appearance, where practicable masonry units for the building should be obtained from the same batch.

Masonry areas that vary in colour are defective if the units are not mixed and/or distributed in accordance with the manufacturer’s installation instructions.

Display panels and display homes may be taken as representative of the range of variations to be expected.

3.07 Masonry facing

Unless documented otherwise, masonry is defective if it is not laid with true, fair or finish face outwards.

Unless documented otherwise, masonry faces are defective if they are not cleaned and free of excess mortar.

3.08 Mortar for masonry

Mortar is defective if it is not in accordance with the requirements of the *Building Code of Australia*.

3.09 Voids and holes in mortar

Voids and holes in mortar in masonry walls, excepting weepholes and vents, are defects if they are visible from a normal viewing position.

3.10 Cracked masonry unit

It is characteristic of some masonry units to have surface cracks or crazing as part of the manufacturing process. These are not defects unless they result in the complete fracture of the unit.

A masonry unit is defective when visible surface cracks exceed a width of 2 mm.

Wall surfaces are defective if they have more than one cracked or crazed unit per square metre.

3.11 Cleaning, mortar smears and stains

Stains, mortar smears and damage caused by cleaning are defects if they are visible from a normal viewing position.

3.12 Masonry tolerances

Where the masonry work fails to conform to the tolerances set out in table 3.04, the work is defective.

MASONRY (CONT)

3.13 Masonry inside garages and similar spaces and under applied finishes

Structural masonry that is visible inside a garage or similar space or through an applied finish is defective if it does not comply with the tolerances in column 1 of table 3.04. However, these tolerances do not apply to the non-face side of single skin masonry.

Non-structural masonry that is visible inside a garage or similar space or through an applied finish is defective if it does not comply with the tolerances in column 2 of table 3.04. However, these tolerances do not apply to the non-face side of single skin masonry.

When there is an applied finish such as render, where the joints are not intended to be visible, masonry need not be saw cut and 1/4 or 3/4 units may be used in lieu of full masonry units.

3.14 Vertical alignment of perpend joints

A line of masonry perpend is defective if it exceeds a maximum deviation from vertical alignment of 15 mm per 2 m height of wall, measured from centre to centre of perpend joints.

3.15 Horizontal alignment of bed joints

Bed joints in walls including adjacent isolated piers and either side of openings and control joints are defective if they are not on the same horizontal plane, or do not comply with item G of table 3.04 of this *Guide*.

3.16 Base bed joint and base row of masonry

Exposed base bed joints above the finished ground level are defective if they exceed 20 mm in thickness.

Base bed joints that are not exposed above the finished ground level are defective if they are greater than 40 mm.

Split masonry units and units on edge used in the base row of units are defective if they are exposed.

3.17 Masonry that overhangs concrete slabs

The installation of a masonry course is defective if it is laid on a concrete slab or strip footing so as to project over the edge of the slab or footing by more than 15 mm. Refer to diagram 4.08.

3.18 Damp proof courses

Damp proof courses are defective if they are not installed in accordance with the *Building Code of Australia*.

3.19 Raking of joints

Where documented, mortar joints in masonry units are defective if they are raked out to a depth of more than 10 mm or are not consistent in depth throughout.

3.20 Brick sills, sill tiles and shrinkage allowance for timber framing

Distortion of window frames and/or dislodgment of sill tiles and sill bricks are defects.

In masonry veneer walls a gap must be left between the timber frame and the top of the masonry wall, window sills etc., to allow for initial settlement of the timber framing caused by timber shrinkage.

MASONRY (CONT)

Work that does not provide the following clearances at the time of construction is defective:

- i. 5 mm at sills of lower and single storey windows; and
- ii. 8 mm at roof overhangs of single storey buildings; and
- iii. 10 mm at sills of second storey windows; and
- iv. 12 mm at roof overhangs to two storey buildings.

Clearances must be doubled if the timber framing is made of unseasoned hardwood.

DIAGRAM 3.20
SHRINKAGE ALLOWANCE FOR TIMBER FRAMING

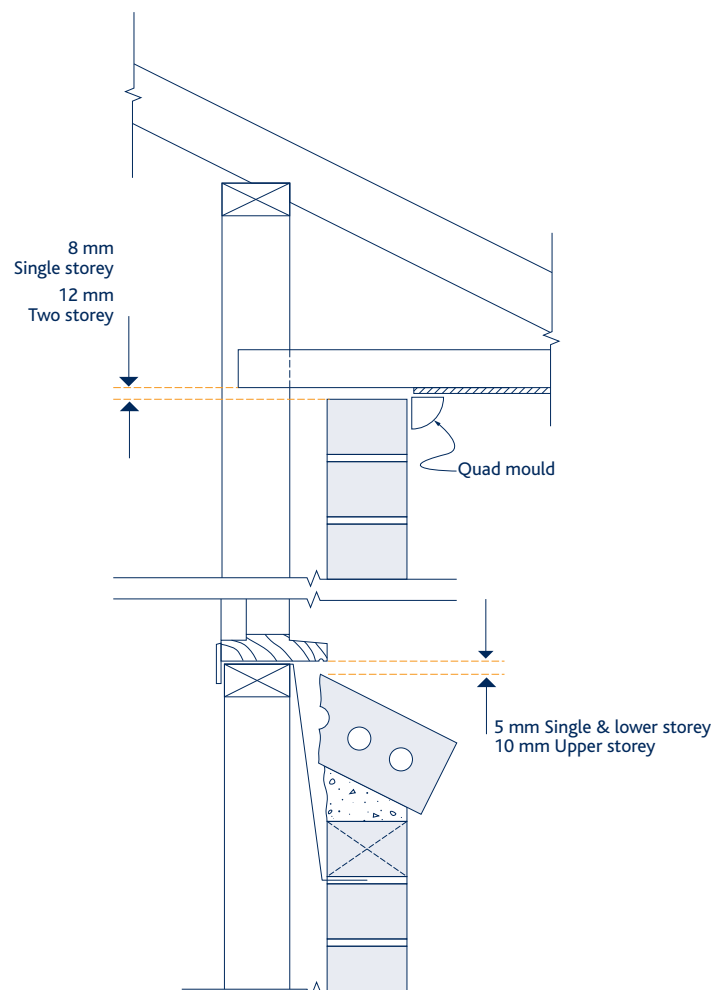

3.21 Sealing of masonry articulation joints

Articulation joints in masonry veneer, single skin masonry or double skin masonry, without a cavity are defective if they have not been sealed.

Unless documented otherwise, flexible mastic or sealant is defective if it does not match as close as practicable the colour of the adjacent surface, and has not been used in accordance with the manufacturer's installation instructions.

FRAMING

4.01 Verticality or plumbness of stumps or piles

Stumps or piles are defective if they deviate from vertical by more than 10 mm in the first 1 m or more than 20 mm in total length, measured from ground level.

DIAGRAM 4.01
VERTICALITY OF STUMPS, POSTS OR PILES

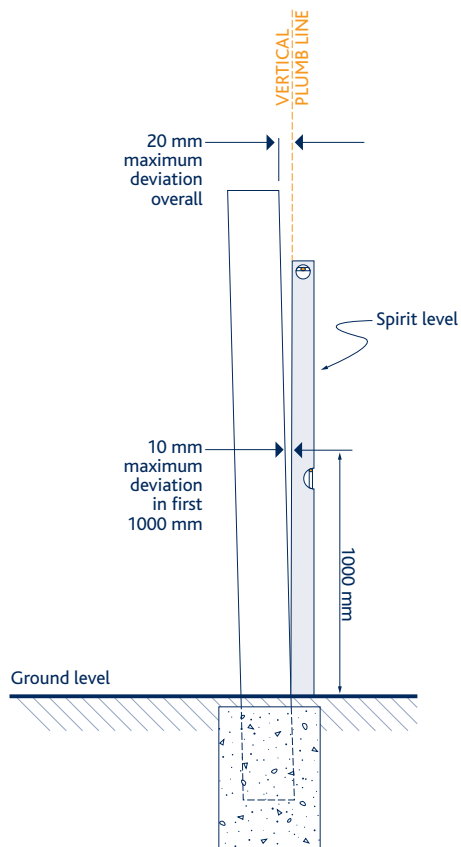
**4.02 Verticality or plumbness of steel and timber frames and exposed posts**

Posts and wall frames are defective if they deviate from vertical by more than 4 mm within any 2 m height. Refer to diagram E on page 11.

4.03 Straightness of steel and timber frame surfaces

Frames are defective if they deviate from plane (horizontal or vertical bow) by more than 4 mm in any 2 m length of wall. Refer to diagram E on page 11.

4.04 Packing under bearers

Packing to stumps or piers under bearers is defective if it is not made of durable, non-compressible materials, such as engineered plastic packers, or does not provide the minimum bearing area required by the *AS 1684 – Residential timber-framed construction*, or is more than a total thickness of 20 mm or is not fixed in a workman like manner.

FRAMING (CONT)

4.05 Timber shrinkage

Timber is defective if it has shrunk more than 10 per cent if it is unseasoned or three per cent if it is seasoned.

4.06 Treads and risers in timber stairs

Timber stairs are defective if they do not comply with the requirements of the *Building Code of Australia*.

The top and bottom risers may be varied to allow for the installation of the approved documented floor finishes, to provide uniform and constant riser height throughout after the installation of the approved floor finishes. This also applies to top and bottom risers of concrete stairs.

A tolerance of up to 5 mm from the nominated dimensions in the approved documents is considered acceptable to allow for the variation in behaviour of timber used in the construction of the stair caused by atmospheric moisture changes.

This tolerance shall not be applied to allow for poor construction practice.

4.07 Fixing stud walls to concrete slabs

Bottom plates must be fixed to concrete slabs in accordance with *AS 1684 – Residential timber-framed construction*.

Depending on the manufacturer's requirements for the concrete nail/masonry anchor used and the required uplift pull-out force and wind category, the distance of the fixing from the edge of the slab is required to be between 50 to 70 mm minimum for standard 20 MPa concrete.

The fixing point cannot be less than five times the diameter of the fastener from the edge of the timber plate which equates to 25 mm for a 5 mm diameter nail and 50 mm for a 10 mm diameter masonry anchor.

FRAMING (CONT)

4.08 Bottom plates that overhang concrete slabs

Bottom plates that are at least 90 mm wide and overhang concrete slabs are defective. An overhang of 10 mm is permissible if the minimum edge distance for both the bottom plate and the concrete slab fixing locations have been satisfied. Minimum cavity widths as required by the *Building Code of Australia* shall be maintained.

DIAGRAM 4.08
BOTTOM PLATES THAT OVERHANG CONCRETE SLABS

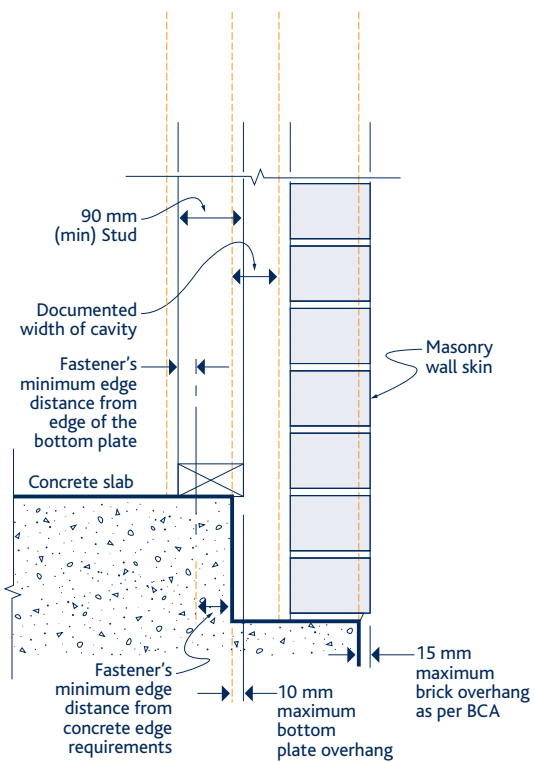

WALL CLADDING

5.01 Leaks in wall cladding

Completed wall cladding and accessories are defective if they leak under normal weather conditions.

5.02 Wall cladding

Staining, folds, splits, dents, open joints between panels, cracking and other distortions in wall cladding are defects if they are visible from a normal viewing position at ground level or an upper floor level.

Any corrosion of metal wall cladding is a defect.

ROOFING

6.01 Flashings and accessories

Completed flashings and accessories are defective if they leak under normal weather conditions.

6.02 Leaks in roofing

Roofing and accessories are defective if they leak under normal weather conditions.

6.03 Roof cladding

Staining, folds, splits, dents, open joints between panels, cracking and other distortions in roof cladding are defects if they are visible from a normal viewing position at ground level or an upper floor level.

Any corrosion of roof cladding is a defect.

6.04 Roof tiles

Roof tiles are defective if they do not conform to the manufacturer's sample. Irregularities in tiles are defects if they are visible from a normal viewing position at ground or upper floor levels.

Minor surface marks or blemishes arising from the tile manufacturing process are not defects.

6.05 Roof tile pointing

Unless documented otherwise, the absence of pointing where required is a defect. Pointing is defective if it becomes dislodged or washed out.

Minor cracking of pointing is not a defect.

The pointing is defective if it is not uniform in colour, texture and trowelled off to provide a neat appearance. The rectification of pointing shall match the existing colour and texture as close as practicable.

6.06 Overhang of roofing (tiles and sheet roofing)

Tiled roofing is defective if tiles overhang the inside face of a gutter by less than 35 mm or by more than 65 mm.

Sheet roofing is defective if it overhangs the inside face of a gutter by less than 50 mm or by more than 65 mm.

DIAGRAM 6.06
OVERHANG FOR ROOFING

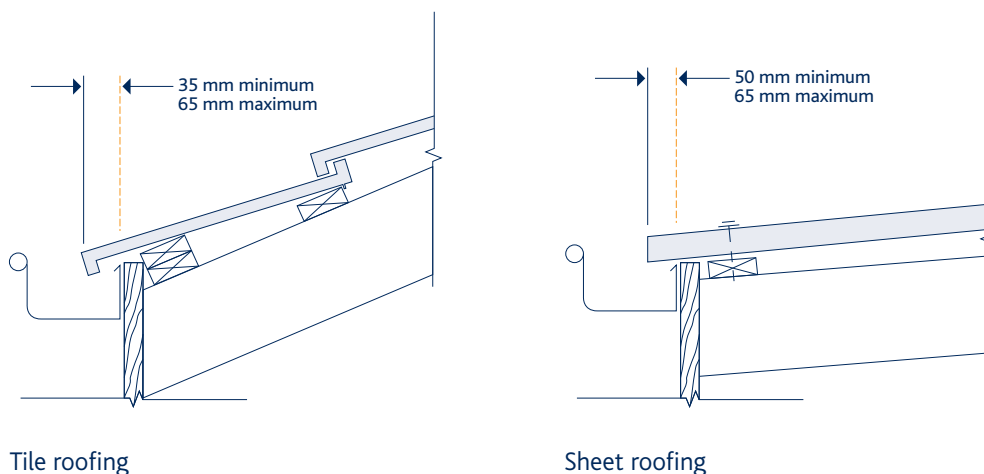

ROOFING (CONT)

6.07 Cutting of roof tiles

Tiles are defective if they are not cut neatly to present a straight line at ridges, hips, verges and valleys.

6.08 Dry valley construction

Dry valleys, where they are documented, are defective if they are not constructed in accordance with the *Building Code of Australia* or any relevant instructions from roofing tile associations or the manufacturer's installation instructions.

6.09 Undulating tiled roof lines

Undulations in the line of roof tiles are defects if the variation exceeds 20 mm in any 4 m length measured in the roof plane.

6.10 Alignment of trusses

Trusses or chords of trusses that bow more than the lesser of $L/200$ or 50 mm are defective; where L is the length of the truss or chord.

6.11 Verticality or plumbness of trusses

Trusses or parts of trusses that are erected with a vertical deviation more than the lesser of $H/50$ or 50 mm are defective, where H is the height of the truss.

DIAGRAM 6.10
ALIGNMENT OF TRUSSES

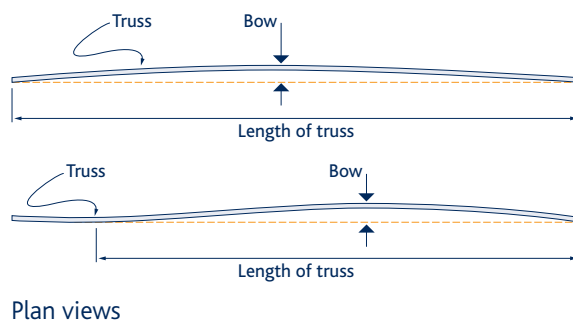
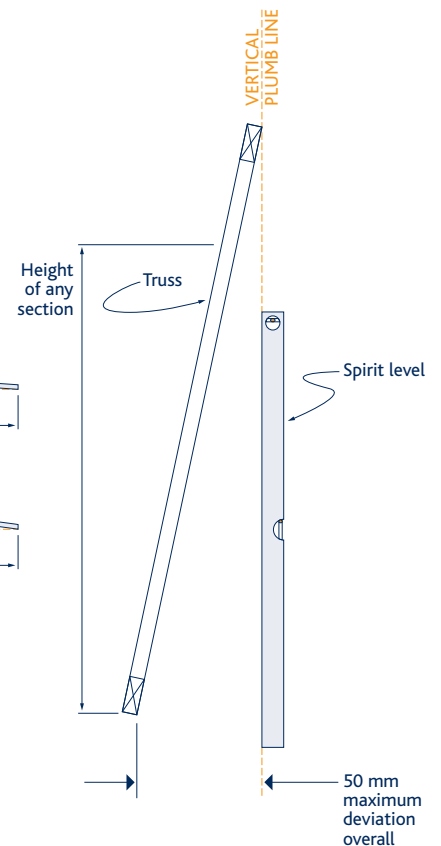

DIAGRAM 6.11
VERTICALITY OR PLUMBNESS
OF TRUSSES



PLUMBING

7.01 Plumbing general

Any plumbing work is defective if it does not comply with the relevant plumbing regulations and the contract documents.

The builder shall provide the owner with a Certificate of Compliance when required by the relevant regulations.

7.02 Positioning of gutters

Unless documented otherwise, installation of gutters is defective if the fascia is visible above a gutter, from a normal viewing position, or the fascia is not finished to match the gutter, or the fascia is not concealed by a flashing finished to match the gutter.

7.03 Water retention in gutters

Gutters are defective if they retain a depth of more than 10 mm of water.

7.04 Joints in gutters

Unless documented otherwise, gutters are defective if they have joints lapped less than 25 mm. Laps that are not in the direction of flow to the outlet, are defective.

Joints that leak are defective.

7.05 Fixing of gutters and downpipes

Gutters and downpipes are defective if they are not securely fixed.

7.06 Flashings

Flashings are defective if they are not provided in accordance with the requirements of the *Building Code of Australia*.

Wall and step flashings, and sloping flashings cut into walls are defective if they do not incorporate weathering folds, anti-capillary breaks and sealing, or do not enter the masonry walls by at least 15 mm as shown in diagram 7.06(A) and (B).

Pressure flashings are defective if they are not fixed on appropriate surfaces, or are not fixed in accordance with diagram 7.06(C).

7.07 Water hammer

Water hammer is a defect unless it is caused by the use of solenoid or ceramic valves in appliances supplied by the owner.

7.08 Pipe penetrations through external walls and inside cupboards

Plumbing holes are defective if they are not properly grouted as appropriate; or in the case of cabinet work, fitted through neat minimum size penetrations, or fitted with tight fitting cover plates or collars with penetrations kept to the smallest size practicable.

7.09 Water discharge from outlets

Water discharge from outlets is defective if it does not drain properly and clears the surrounds of vessels such as baths, basins, troughs or sinks.

DIAGRAM 7.06 (OVER PAGE) FLASHINGS

DIAGRAM 7.06
FLASHINGS

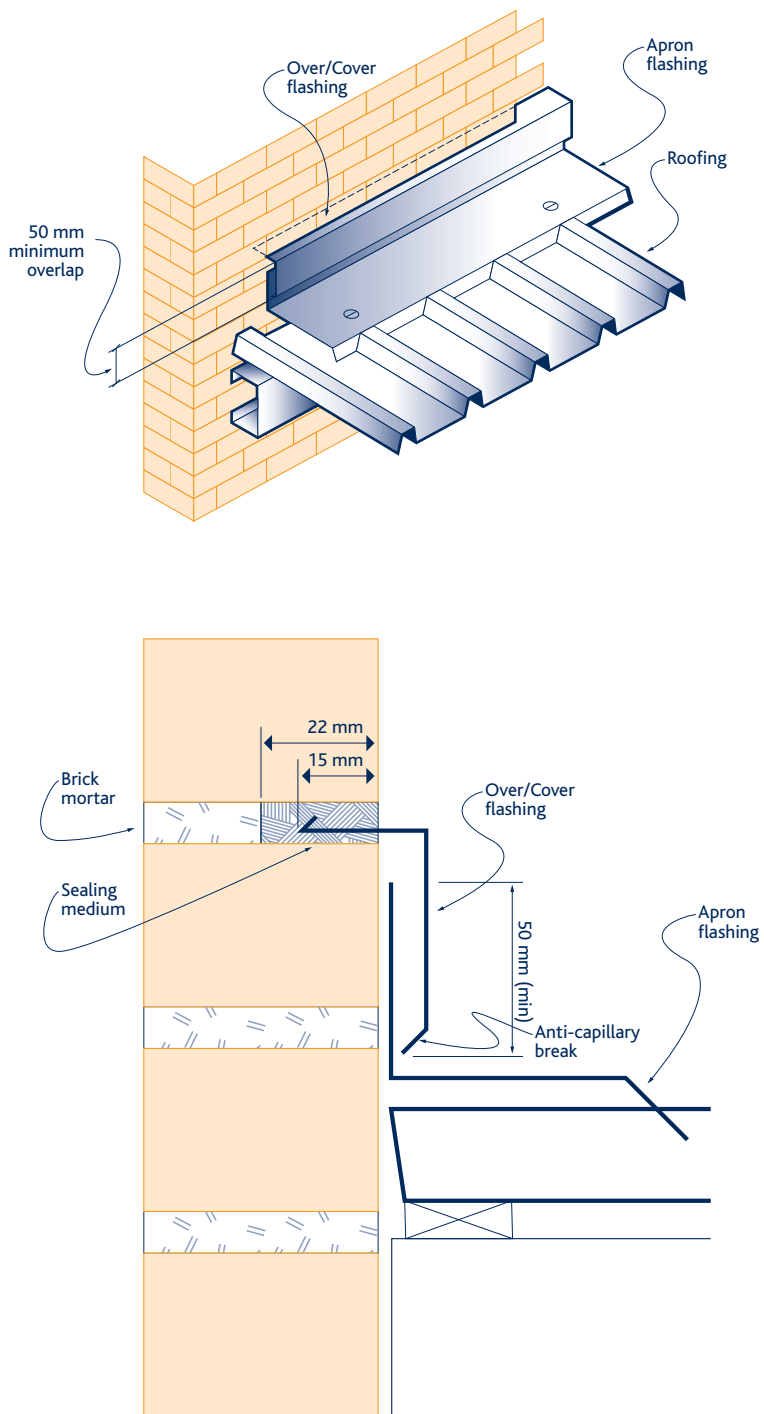

A) Traditional raked joint and step method

PLUMBING (CONT)

DIAGRAM 7.06
FLASHINGS

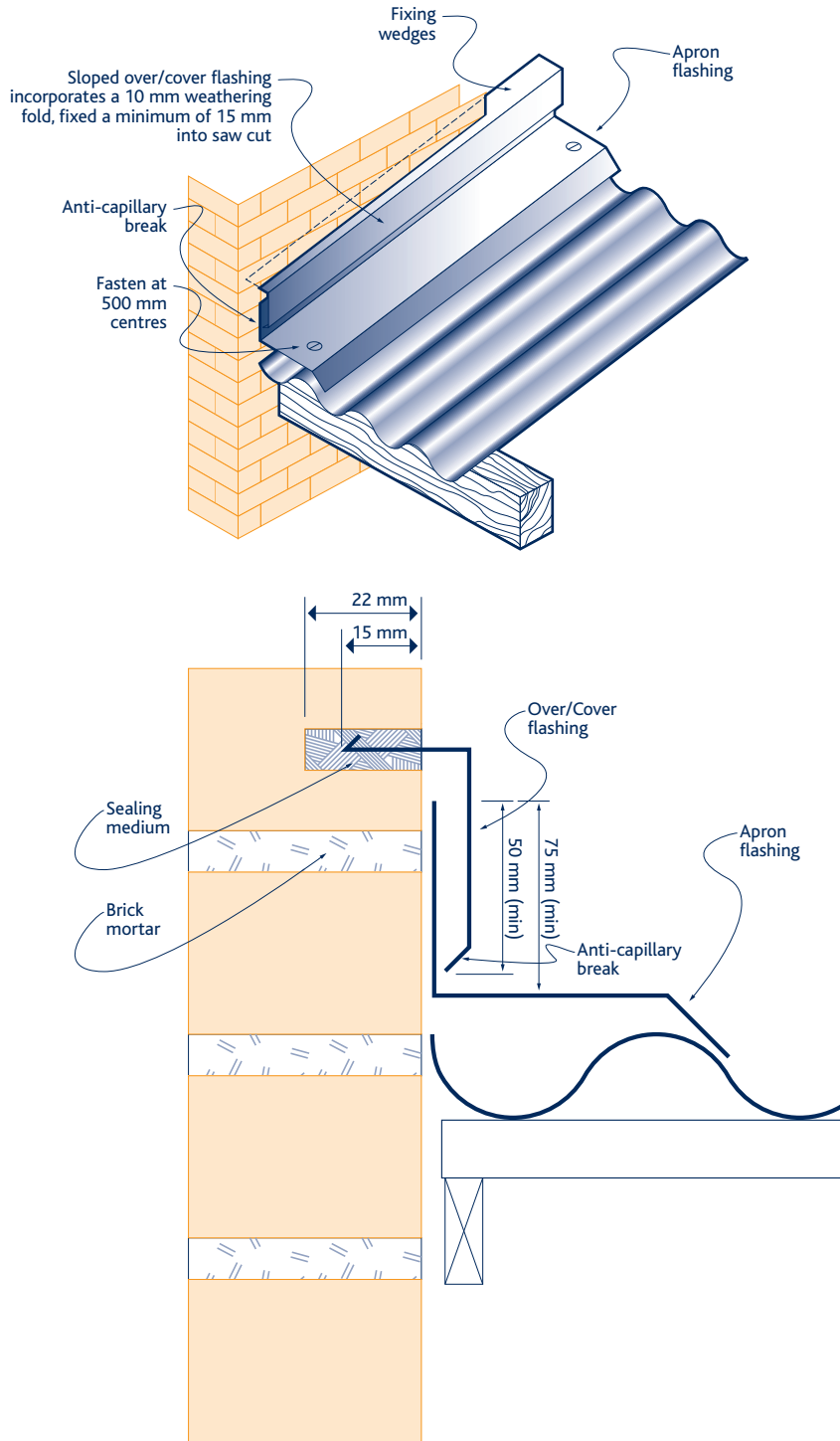

B) Sloping wall cut method

DIAGRAM 7.06
FLASHINGS

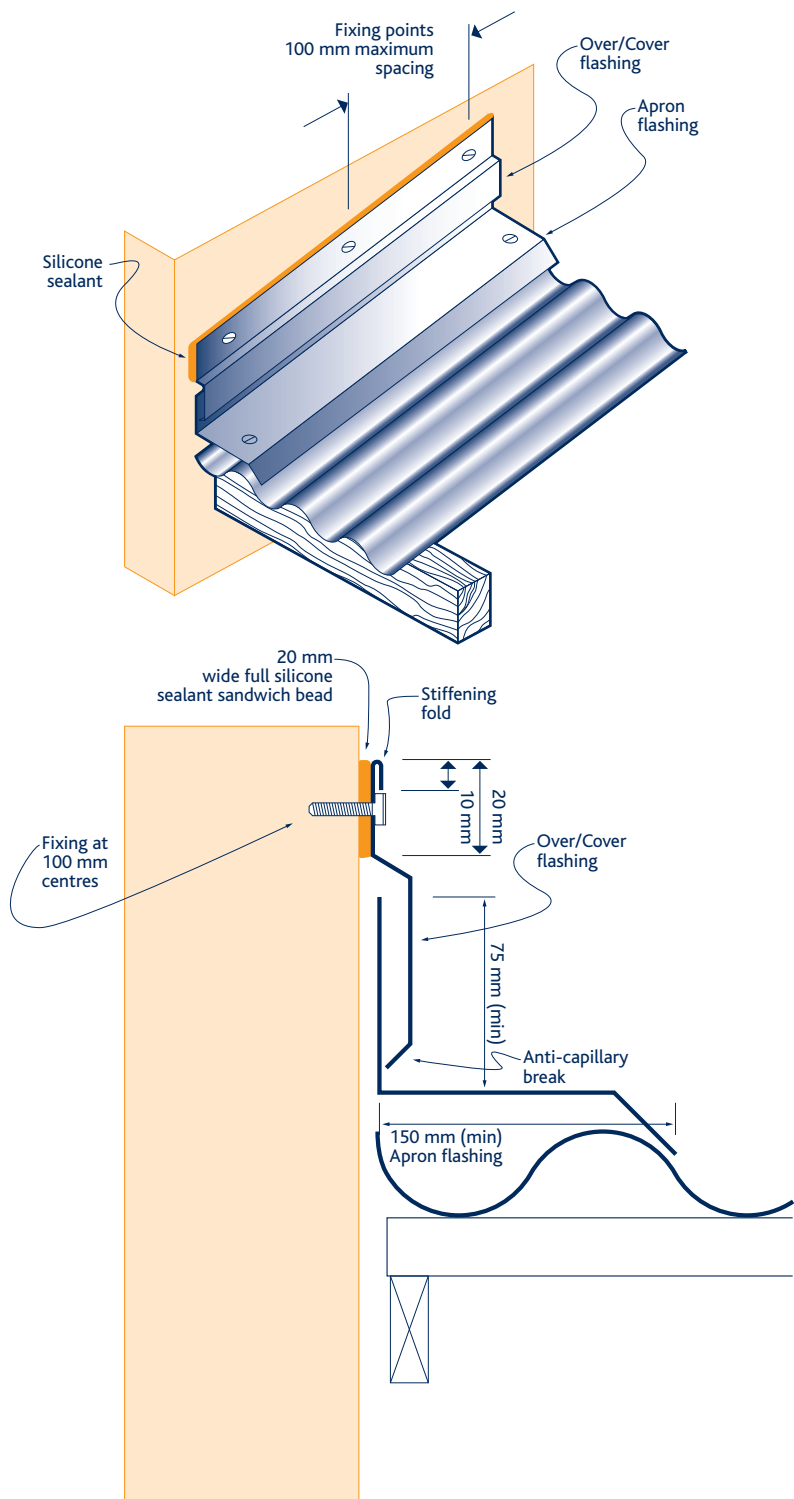

C) Pressure flashing

WINDOWS AND DOORS

8.01 Installation of external windows and doors

Unless documented otherwise, external windows and doors are defective if they are not installed and flashed to the manufacturer's installation instructions.

8.02 Weather-tightness of windows, doors and window and door frames

Window and door frame installations are defective if they allow water to penetrate to rooms under normal weather conditions.

Windows and doors are defective if, when closed, they allow the entry of water to rooms.

Water entry, through doors is not a defect if they are not intended to prevent water entry. For example, vehicle access doors.

8.03 Door handles, locks and latches

During the documented maintenance period after completion, handles, locks and latches are defective if they do not operate as intended by the manufacturer. If the maintenance period is not documented, three months is the assumed time period after completion. After the end of the maintenance period, failure is not a defect unless it is caused by the builder's workmanship.

8.04 Internal door clearances

Unless documented otherwise, the installation of doors is defective if within three months of completion, clearances between door leaves and frames and between adjacent door leaves are not uniform and within 1 mm of the documented dimension.

If not otherwise documented:

- a) A clearance between door leaves or between a door leaf and the frame is defective if it is less than 2 mm or greater than 5 mm in width
- b) Unless additional clearance is required for removable toilet doors or air ventilation, a clearance between the door and the floor finish is defective if it is greater than 20 mm after installation of the floor covering.

Note: Clearances under doors will generally be determined by the nominated floor coverings.

8.05 Distortion of doors

Door leaves are defective if, during the initial three months they twist or bend greater than the limits listed below.

Distortion of doors	Limit
Twisting measured diagonally across door	5 mm
Bending in door heights up to 2150 mm high	4 mm
Bending in door heights between 2150 and 2400 mm high	6 mm
Bending in door heights over 2400 mm high	7 mm
Bending in door widths up to 1020 mm wide	2 mm
Surface (face) misalignment, at the meeting edges of double swing or French doors, when the doors are fully closed	5 mm



WINDOWS AND DOORS

8.06 Sealing of door edges

Door leaves are defective if they do not have all sides, top and bottom edges that are sealed to prevent moisture entering.

8.07 Operation of windows and doors

Doors and windows are defective if they bind or jam as a result of the builder's work.

Doors and windows are defective if they do not operate as intended by the manufacturer.

8.08 Bowed window heads, sills and jambs

Sills, heads or jambs, that have horizontal or vertical deviations (bow) from a plane surface greater than the dimensions stated in *AS 2047- Windows in buildings - Selection and installation* or proportional equivalent, are defective.

All clearances shall be sufficient to enable installation of the windows to be plumb, level and not allow loads to be imposed on the windows.

Refer also to 3.20 Brick sills, sill tiles and shrinkage allowances for timber framing.

PLASTERING AND RENDERING

9.01 Matching and repairing existing rendered surfaces

The builder must try to match existing work.

In some instances this may not be possible as the original finish may have significantly aged or the material composition may be impossible to determine without expensive research.

When matching an existing finish, a practical approach must be adopted, and where possible a physical joint, a door, a window, a downpipe or other similar separator should be incorporated to lessen the visual impact of the new work. Where this is not possible, the whole of that wall from corner to corner should be re-finished.

Generally, painting pre-coloured render, to hide defects, is not recommended as this significantly changes texture and appearance.

Where appropriate, defective work such as cracking should be monitored for 12 months or any other agreed period, before determining what, if any remedial work is required.

9.02 Cracking and other blemishes in external rendered surfaces on masonry substrate

Assess crack categories and defects in external rendered surfaces on masonry substrate in accordance with clause 3.02.

Obvious spot rust marks, due to the composition of the material and other blemishes, are defects if they are visible from a normal viewing position.

9.03 Repairs to external applied finishes

Repairs to surfaces that have been rendered are defective if they do not match the colour and texture of the remaining wall or adjacent area as close as practicable.

9.04 Articulation or control joints – provision and cracking

Unless documented otherwise, cracks in external rendered surfaces are defects if recommended articulation or control joints have not been installed.

Articulation or control joints are defective if they do not extend through the full width of masonry skin.

With the exception of paint and recommended mastic sealants, render or other applied finishes are defective if they cover articulation or control joints.

9.05 Covering articulation or control joints and damp-proof courses

Mouldings and inflexible covering strips are defective if they are installed across articulation or control joints and are fixed or restrained on both sides.

Applied finishes are defective if they impede the performance of any damp-proof course or sub-floor ventilation required in accordance with the *Building Code of Australia*.

Unless documented otherwise, flexible mastic or sealant is defective if it does not match as close as practicable the colour of the adjacent surface and has not been used in accordance with the manufacturer's installation instructions.

PLASTERING AND RENDERING (CONT)

9.06 Cracking in external applied finishes used over lightweight substrate

Cracks or open joints in external finishes applied to lightweight substrate are defects if they are greater than 1 mm and are visible from a normal viewing position within the first 24 months.

Cracks or open joints in external finishes (excluding painting) applied to lightweight sheet substrate are defects if they allow the ingress of water.

9.07 Cracks in internal rendered finishes including hard plaster

Assess crack categories and defects in internal rendered surfaces on masonry substrate in accordance with clause 3.02.

9.08 Rendered surfaces

Rendered or hard plastered surfaces are defective if they do not conform to the documented surface, sample or description.

9.09 Cracking in external mouldings

Cracks in mouldings and/or other architectural features, including joints between those feature and adjacent surfaces, are defects if they are greater than 2 mm and are visible from a normal viewing position within the first 24 months.

9.10 Verticality or plumbness of internal and external wall surfaces

Wall surfaces are defective if they deviate from vertical by more than 4 mm within any 2 m height. Refer to diagram E on page 11.

9.11 Straightness of internal and external wall surfaces

Walls are defective if they deviate from plane (bow) by more than 4 mm within any 2 m length of wall. This tolerance includes internal walls with a build up of plaster at internal and external corners of the plasterwork. Refer to diagram E on page 11.

9.12 Plasterboard sheeting

The installation and jointing of plasterboard sheeting systems is defective if it does not conform to *AS/NZS 2589.1 - Gypsum linings in residential and light commercial construction - Application and finishing - Gypsum plasterboard* and the manufacturer's installation instructions.

9.13 Defects in other sheeting systems

Defects in the installation of other sheeting systems such as fibre cement sheeting shall be assessed in the same manner as plasterboard sheeting.

9.14 Level of finish for plasterboard

Unless documented otherwise, a Level 4 finish, as shown in table 9.14, is to be adopted as the required standard for domestic plasterboard surfaces.

Unless documented otherwise, plasterboard in pantries, built-in wardrobes, cupboards, under-stairs and storage areas is defective if it does not have at least a Level 4 finish.

PLASTERING AND RENDERING (CONT)

TABLE 9.14
LEVELS OF FINISH FOR PLASTERBOARD

Level	Level of finish
Level 0	This level of finish may be useful in temporary construction. No stopping, taping, finishing or accessories are required. The work is confined to gluing or screwing/nailing sheets in place.
Level 1	For use in plenum areas above ceilings, in areas where the work would generally be concealed, or in building service corridors and other areas not normally open to public view. All joints and interior angles shall have tape embedded in joint compound. Surface shall be free of excess joint compound. Tool marks and ridges are generally acceptable with accessories optional at specifier's discretion in corridors and other areas with pedestrian traffic.
Level 2	For use in warehouse, storage or other similar areas where surface appearance is not of primary concern. All joints and interior angles shall have tape embedded in joint compound and one separate coat of joint compound applied over all joints and fastener heads. Surface shall be free of excess joint compound. Some minor tool marks and visible edges are generally acceptable.
Level 3	For use in areas which are to receive heavy or medium texture (spray or hand applied) finishes or where heavy wall covering paper are to be applied as the final decoration. This level of finish is not generally suitable where smooth painted surfaces or light to medium weight wall coverings are documented. All joints and interior angles shall have tape embedded in joint compound and one separate coat of joint compound applied over all joints and fastener heads. All joint compound shall be finished smooth. (Generally this is achieved by scraping off nibs and ridges and the like, with the edge of a trowel.)
Level 4	This is generally the accepted level of finish for domestic construction. It is used where light textures or wall coverings and smooth textured finishes are illuminated by critical lighting and where smooth textured finishes and satin/flat/low sheen paints are illuminated by non-critical lighting. In critical lighting areas, flat paints applied over light textures tend to conceal joints. Gloss and semi-gloss paints are not generally suitable over this level of finish. The weight, texture and sheen level of wall coverings applied over this level of finish should be carefully evaluated. Joints and fasteners must be adequately concealed if the wall covering material is lightweight, contains limited pattern, has a gloss finish, or has any combination of these features. All joints and interior angles shall have tape embedded in joint compound and a minimum of two separate coats of joint compound applied over all joints, angles, fastener heads and accessories. All joint compound shall be finished smooth and be free of tool marks and ridges.
Level 5	This level of finish is for use where gloss or semi-gloss paints are documented or where critical lighting conditions occur on satin, flat or low sheen paints. All joints and interior angles shall have tape embedded in joint compound and a minimum of two separate coats of joint compound applied over all joints, angles, fastener heads and accessories. All joint compound shall be finished smooth and be free of tool marks and ridges. This shall be followed by proprietary surface preparations or (in some areas) skim coating to remove differential surface textures and porosity.

Based on: AS/NZ 2589.1: Section 6.6 Levels of Finishes for Plasterboard Surfaces

Refer to notes on the following page

PLASTERING AND RENDERING (CONT)

TABLE 9.14 (CONT)
LEVELS OF FINISH FOR PLASTERBOARD

Notes to table 9.14

1. Skim coating is a term denoting a thin finish coat, trowelled or airless sprayed to achieve a smooth finish. It is a thin coat of joint compound over the entire surface to fill imperfections in the joint work, smooth the paper texture and provide a uniform surface for decorating. Skim coatings would not normally exceed 1 mm in finished thickness.
2. Advice should be sought prior to finish for gloss paints or in areas of critical lighting.
3. Critical lighting occurs when the light source is nearly parallel to the wall or ceiling surface.
4. Non-critical lighting occurs when the light that strikes the surface is diffused and not parallel to that surface.

9.15 Cracking in plasterboard, hard plaster and other plaster elements

Cracking in walls, ceilings and bulkheads that is greater than 1 mm is a defect if it is visible from a normal viewing position³. Cracking in recessed and butt joints is a defect if it is visible from a normal viewing position.

9.16 Cracking in cornices

Cracking of cornice joints such as butt joints and mitres, and at junctions with walls and ceilings is a defect if it is greater than 1 mm and can be seen from a normal viewing position.

9.17 Cracking at junctions of dissimilar materials

Cracking at junctions between dissimilar materials is a defect if it is greater than 1 mm or is visible from a normal viewing position⁴.

9.18 Straightness and alignment of plaster cornices

Plaster cornices are defective if they deviate from a straight line greater than 4 mm over a length of up to 2 m.

9.19 Peaking or jointing in plasterboard

Plaster peaking or jointing is a defect if it is visible from a normal viewing position⁵.

9.20 Nail popping in plasterboard

Nail popping in plasterboard sheeting is a defect if it occurs within the first 24 months.

³ Where diagonal cracking occurs in plasterboard consider the underlying cause.

⁴ Consider installing movement control joints or mouldings in these locations.

⁵ CSIRO Report No L8 and TR90/1 *Illumination and decoration of flat surfaces* should also be consulted.

INTERNAL FIXING

10.01 Gaps associated with internal fixing

Unless documented otherwise, gaps between mouldings or between mouldings and other fixtures, at mitre or butt joints, or at junctions with a wall or other surfaces are defects if they exceed 1 mm in width, occur within the first 12 months and are visible from a normal viewing position. After the first 12 months gaps exceeding 2 mm are considered defective.

10.02 Joints in fixing of internal mouldings

Unless documented otherwise, the faces of architraves and skirtings are defective if they are not aligned and flush at mitres and butt joints and the misalignment can be seen from a normal viewing position.

10.03 Architrave quirks

The width of the quirk (setback from the edge) of each length of an architrave is defective if it is not consistent and where the irregularity can be seen from a normal viewing position.

10.04 Cabinet doors and drawer fronts⁶

Unless otherwise specified cabinet door and drawer fronts are defective if they are not aligned at completion, or do not have consistent gaps between doors and between drawers.

Where the time limit for defects in cabinet doors, drawer fronts and similar joinery is not documented it is to be taken as six months from completion.

10.05 Natural materials

Materials such as timber, granite and marble are natural products that may have blemishes and variations in pattern and colour that are natural characteristics of the material.

Stone materials are often brittle and may be easily cracked. Polished stone surfaces can be porous and subject to staining.

10.06 Natural stone surfaces

Any cracking, displacement, pitting or similar blemishes in natural stone, marble or similar materials are defects if they are caused by the builder and can be seen from a normal viewing position.

10.07 Replacing defective work of natural stone or similar materials

Replacement stone or similar material is defective if the replacement material does not match the adjacent areas. If matching of stone is not possible, the whole area of stone shall be replaced⁷.

10.08 Joints in timber, stone and laminated bench tops

Bench tops of timber, laminate, natural stone or similar materials are defective if they have joints that are not uniform, close-fitted, aligned and in the same plane.

These requirements also apply to vertical surfaces of similar material and finish.

Joints are defective if they are not sealed or flush-filled with a suitable flexible sealant of matching colour.

10.09 Sealing around benches and items installed in benches

Where required, junctions between bench tops and adjoining surfaces are defective if they are not sealed with an agreed or suitable flexible sealant of matching colour.

Sealing around items such as sinks, hand basins etc., is defective if the joint leaks, or if it is not carried out in accordance with the manufacturer's installation instructions.

⁶ Refer also to *AS/NZS 4386.1 Domestic kitchen assemblies – Kitchen units*

⁷ In these circumstances it is not normally necessary to replace areas of the material that are not adjacent to and contiguous with the affected area.

FLOOR AND WALL TILING

11.01 Floor and wall tiling

Unless documented otherwise, tiling work and materials must comply with *AS3958.1: Ceramic tiles – Guide to the installation of ceramic tiles*, *AS3958.2: Ceramic tiles – Guide to the selection of a ceramic tiling system* and the manufacturer's installation instructions for the materials selected.

The builder is responsible for tiling that fails because of defective builder's work in framing or slab construction including tiling not laid by the builder.

Where the builder has to match tiles that are no longer available, a practical approach must be adopted. The use of a slightly different tile is not a defect if it is used with the written agreement of the owner.

Where non-matching tiles have to be used, a joint location such as the aluminium channel of a shower screen, a separating doorway, an intersecting wall, a change in wall direction or similar should be selected to separate the different tiles.

11.02 Floor and wall tiling where the builder supplies the tiles

Where the supply and laying of tiles is by the builder as part of the building contract, the failure of the tiles, substrate, adhesive or grout is a defect.

11.03 Floor and wall tiling where the owner supplies the tiles for laying by builder

Faulty installation of tiles is defective if caused by the builder's workmanship.

Any fault in the tiles is the responsibility of the owner - except where faults in the tiles should have been apparent to the builder at the time of laying.

11.04 Floor and wall tiles where the owner supplies and lays the tiles

The owner is responsible for checking the adequacy of the substrate before laying the tiles. Any failure of tiles, adhesive or grout, where the owner supplies and lays the tiles, is the responsibility of the owner.

11.05 Cracked, pitted, chipped, scratched, loose or drummy tiles

Tiles are defective if they are cracked, pitted, chipped, scratched, loose or drummy on completion.

After handover, tiles are defective when caused by the builder's workmanship, they become cracked, pitted, chipped, loose or drummy and such in more than five per cent of the tiled area within 24 months from completion.

FLOOR AND WALL TILING (CONT)

11.06 Grout

Grouting is defective if it is not installed to the requirements of *AS3958.1, Ceramic tiles – Guide to the installation of ceramic tiles*.

Grout lines are defective if they are not, as far as practicable, of consistent width.

Finished grout is defective if it is not uniform in colour and is not smooth, without voids, pinholes or low spots and finished to the cushion on cushion edged tiles and flush with square edge tiles, except for tooling in accordance with *AS 3958.1 - Ceramic tiles – Guide to the installation of ceramic tiles, clause 5.7.1 (e)*⁸.

Grout is defective if it becomes loose within 24 months of completion.

11.07 Flexible sealants to junctions

Flexible or waterproof sealants to junctions are defective if they are not installed when required by the *Building Code of Australia* and *AS 3958.1 - Ceramic tiles – Guide to the installation of ceramic tiles*, or in accordance with the requirements of the manufacturer.

11.08 Uneven tiling

Except where tiles have distortions inherent in the manufacture, tiling is defective if it has joints that are not uniform, of even width, aligned or in the same plane.

Large tiles could present problems when required to fall and drain to a floor outlet.

⁸ *AS 3958.1 clause 5.7.1 (e)* states that the top surface of the grout may be tooled to provide a contoured depression of no deeper than 1 mm for up to 6 mm wide joint and up to 2 mm for a 6 – 10 mm wide joint.

PAINTING

12.01 Standard of painting

Coatings used are to be suitable for the relevant conditions and relevant wear and tear.

Unless documented otherwise, painting is defective if it does not comply with the manufacturer's installation instructions or *AS/NZS 2311 - Guide to the painting of buildings*.

12.02 Surface finish of paintwork

Paintwork is defective if application defects or blemishes such as paint runs, paint sags, wrinkling, dust, bare or starved painted areas, colour variations, surface cracks, irregular and coarse brush marks, sanding marks, blistering, uniformity of gloss level and other irregularities in the surface that are visible from a normal viewing position.

Excessive over-painting of fittings, trims, skirtings, architraves, glazing and other finished edges is a defect.

12.03 Nail and screw fixings

Fixings or unfilled depressions caused by fixings are defects in painted or stained surfaces if they can be seen from a normal viewing position.

12.04 Mechanical damage and natural defects in surfaces

Holes and any other unfilled depressions in painted or stained timber such as surface defects caused by mechanical damage, natural characteristics such as gum pockets or surface splits are defects if they can be seen from a normal viewing position.

12.05 Paint durability

Unless documented otherwise, coatings are defective if they fail by lifting, blistering, flaking, fading etc. within the minimum period shown in table 12.05.

TABLE 12.05
MINIMUM DURABILITY OF COATED FINISHES

Coating	Minimum durability
Exterior acrylic	36 months
Exterior enamel	24 months
Exterior semitransparent stains	12 months
Exterior clear finishes	not recommended
Interior – all finishes	36 months

WET AREAS, DECKS AND BALCONIES

13.01 Wet areas

Shower recesses, decks and balconies frequently fail because of inadequate attention to the correct selection of materials and proper water proofing techniques. Care must be taken during design and construction to prevent water penetration from these areas into the dwelling.

Rectification is often expensive because it involves rebuilding the area affected to achieve a long-term water proofing solution.

Users can subject shower recess components to excessive stress, and failures caused by such wear and tear are not defects.

Water proofing to wet areas is defective if not installed in accordance with the requirements of the *Building Code of Australia*.

13.02 Flashings generally

Flashings are defective if they are not installed in accordance with the requirements of the *Building Code of Australia*.

13.03 Shower recess and components

Shower recess and components are defective if they crack, leak or don't perform as intended.

Cracks in shower bases, screens and glass are defects if they are visible from normal viewing position.

Any shower component that allows the shower recess to leak during normal usage is defective.

13.04 Leaks in water proof decks and balconies

Water proof decks and balconies that leak are defective.

13.05 Water proof decks and balconies substrate

Water proof decks and balconies are defective if they are constructed with substrate of non external quality water resistant materials such as particleboard referred to in *AS 1860 - Installation of particleboard flooring*, or other materials that are not warranted as suitable by the manufacturer for that purpose, whether or not they fail.

Water proof decks and balconies are defective if the water proofing system is not installed in accordance with the manufacturer's installation instructions.

13.06 Decks and balcony freeboard outside windows and doors

Unless documented otherwise, water proof decks and balconies are defective if they do not have a drainage system sufficient to withstand wind-driven water surging from the deck or balcony such as a water proofed freeboard or step-down⁹.

13.07 Leaking and ponding of water proof decks and balconies

Water proof decks and balconies are defective if they leak, pond water and/or do not drain to the outer edge, or storm water outlet.

13.08 Calcification and efflorescence associated with decks and balconies

Calcification or efflorescence caused by water coming from a deck or balcony that occurs on walls below or beside the deck or balcony; or that appears in the mortar joints of the deck or balcony tiling, is a defect. Activities of others, such as owners watering plants, may also contribute to the efflorescence, which may not be attributed to the work of the builder.

⁹ Refer to AS 3500.3, *Plumbing and drainage - Stormwater drainage*

FLOORS

14.01 Timber flooring

Timber flooring will shrink or swell according to its internal moisture content and the timber species used. The internal moisture content will adjust to the surrounding atmosphere after the timber is installed and this may lead to permanent or seasonal swelling or cracking.

Care should be taken to adjust the moisture content of the timber, as far as practical, to the prevailing conditions before installation in accordance with the manufacturer's installation instructions. Even so, some minor movement is to be expected.

Exposure to sunlight, cooling, heating or other heat generating appliances is likely to cause localised shrinkage of timber that cannot be allowed for at the time of construction. This is to be taken into consideration when determining if there is defective workmanship.

14.02 Timber flooring generally

Flooring, including tongue and groove strip flooring; structural plywood and particleboard sheet flooring, is defective if it is not installed according to *AS 1684 – Residential timber-framed construction* and the manufacturer's installation instructions.

Floating floors which rest on the structural floor are defective if not installed in accordance with the manufacturer's installation instructions.

14.03 Gaps in exposed timber flooring

Except where affected by exposure to sunlight, cooling, heating or other heat generating appliances, flooring is defective if it has a gap of more than 2 mm between adjacent boards that extend for more than 1 m. Flooring is defective if it has gaps of more than 5 mm in total of three gaps between four consecutive boards¹⁰.

14.04 Joint swelling in timber, plywood and particleboard flooring

Joints in plywood and particleboard floors are defective if they can be detected through normal floor coverings.

Swelling in tongue and groove timber flooring is a defect if it causes buckling of the boards or movement of perimeter restraints such as walls¹¹.

¹⁰ Flooring with gaps that exceed the allowances stated above is not defective when the builder in writing has made the owners aware that the flooring system installed could suffer significant shrinkage and has obtained this acknowledgement in writing.

¹¹ Builders should take care to provide for expansion around the perimeter of the floor and to provide adequate sub floor ventilation.

FLOORS (CONT)

14.05 Nail popping in timber, plywood and particleboard floors¹²

Nail heads that can be detected through floor coverings or nail popping that is clearly visible in exposed flooring are defects if they occur within the first 24 months.

14.06 Squeaking floors

Floors that squeak in trafficable areas within the first 24 months are defective.

14.07 Springy floors

Floors that bounce in a way that can be detected by a person walking normally across the area are defective unless the substructure has been constructed in accordance with *AS. 1684 – Residential timber-framed construction*.

14.08 Timber floor levels

Floor levels within a room or area are defective if they differ by more than 10 mm in any room or area, or more than 4 mm in any 2 m length.

The overall deviation of floor level to entire building footprint shall not exceed 20 mm. Refer to clause I of this *Guide* where the new floor is to join an existing floor.

14.09 Splitting of timber decking

Splits in timber decking that extend to the end or side edge of the timber are defects if they are due to the fixing method.

¹² Owners who undertake their own floor polishing of exposed flooring or who lay floor coverings after completion of the builder's works are responsible to ensure that all nails and other fixings are properly punched or countersunk and stopped.

15/

16/

17/

ELECTRICAL

15.01 Electrical generally

Any electrical work is defective if it does not comply with the relevant regulations or the project documents.

If the owner is not provided with a Certificate of Electrical Safety or the equivalent where this is required by the relevant legislation, the work is defective.

POOLS AND SPAS

16.01 Concrete pools and spas

Concrete pools and spas are defective if they do not comply with AS 2783 - *Use of reinforced concrete for small swimming pools*.

16.02 Premoulded fibre-reinforced plastic pools and spas

Premoulded pools and spas are defective if they are not installed in accordance with AS/NZS 1839 – *Swimming pools - Premoulded fibre-reinforced plastics – Installation*.

16.03 Variations from documented dimensions in concrete pools

Departures from the documented set out for concrete pools are defects if they exceed L/100, where L is the documented dimension, or 5 mm, whichever is the greater.

16.04 Variations from documented datum in concrete pools and spas

Set outs that depart from documented RL or FFL by more than 40 mm, are defective.

RESTUMPING

17.01 Restumping

Owners should understand the limitations imposed on re-leveling of existing structures by such factors as:

- » Existing structural conditions;
- » Fixed points, such as chimney hearths;
- » Attached buildings;
- » Extensions to the dwelling;
- » Plumbing installations;
- » Likelihood of consequential damage to wall claddings; or
- » Any other factor that may restrict the re-leveling process.

RESTUMPING (CONT)

17.02 Consequential damage due to restumping

Consequential damage caused by restumping works is not a defect where the builder has documented evidence that the owner has been informed of the nature and likelihood of such damage.

In the absence of such documented evidence, consequential damage caused by restumping work is a defect.

17.03 Floor levels after restumping

Except where documented otherwise, relevelled floors are defective if they differ in level by more than 15 mm in any room or area, or more than 8 mm in any 2 m length.

GENERAL

18.01 Appliances and fittings

The owner is responsible for organising warranty service for faults in appliances and fittings supplied as part of the building contract where the builder has provided the warranty documents to the owner. Service outside the warranty period is the responsibility of the owner.

18.02 Faults and damage to appliances and fittings

Damage to appliances and fittings supplied as part of the building contract are defects if it is due to the builder's workmanship.

During the documented maintenance period after completion, fittings are defective if they do not operate as intended by the manufacturer. If the maintenance period is not documented it is to be taken as three months. After the end of the maintenance period failure is not a defect unless it is caused by the builder's workmanship.

18.03 Condensation

Condensation is a common problem in buildings, particularly in bathrooms and laundries, and can occur on windows, under unlined roofs or elsewhere. Where the requirements of the *Building Code of Australia* have been complied with, the responsibility for controlling condensation by maintaining adequate ventilation through the installation and use of exhaust fans or other means is the responsibility of the owner.

Condensation is a defect if the builder has not complied with the relevant clauses of the *Building Code of Australia*.

18.04 Glazing

Scratches, fractures, chips or other blemishes on glazing and mirrors are defects if they are caused by the builder and can be seen from a normal viewing position.

Minor scratches, fractures, chips or other blemishes that are not more than 10 mm long and where there are not more than three blemishes per pane, are not defects.

18.05 Lyctus borer

Timber is defective if it is used during construction with evidence of lyctus borer attack, unless the timber product has been approved by the manufacturer.

GENERAL (CONT)

18.06 Termites and white ants

Termites or white ants are a widespread problem in all areas of Australia and it is the owner's responsibility to regularly inspect the property, including sub-floor inspections, to detect evidence of termite attack.

Termites can circumvent properly executed termite protection measures by, for example, building tunnels around barriers. Tunnels can be identified through regular inspections and, if found, the termite nest should be located and destroyed by suitably qualified pest controllers.

18.07 Termites or white ant damage

Damage caused by termites or white ants that occurs in areas not designated by the relevant council as a termite prone area are the responsibility of the owner.

Damage caused by termites and white ants that are found in buildings within designated termite prone areas is a defect if the termite management system has not been installed and maintained in accordance with the *Building Code of Australia*.

18.08 Water leaks

Roofs, gutters, flashings, skylights, window and door frame joints or seals are defective if they leak under normal weather conditions, providing they have been properly maintained by the owner¹³.

18.09 Cleaning

Owners are entitled to expect that the building site and works are clean and tidy on completion. Where handover is delayed for any reason the owner must expect that dust may have settled on interior exposed surfaces.

Building sites are defective if, upon handover, they are not clear of building debris.

Building works are defective where windows are not clean, floors are not swept, mopped or vacuumed as appropriate, tiles, sinks, basins, troughs, baths, etc. are not cleaned and shelving, drawers and cupboards ready for use.

18.10 Maintenance

Maintenance is a normal part of home ownership and the owner is responsible for all maintenance.

Owners should refer to CSIRO publication: *Guide to Home Owners on Foundation Maintenance and Footing Performance*.

¹³ Proper maintenance by the owner includes regular de-leafing of gutters and maintaining protective coating systems around window and door frames.

APPENDIX

Relevant legislation

These principal documents are applicable to domestic building construction in the following jurisdictions:

Victoria

- » *Building Act 1993*
- » *Domestic Building Contracts Act 1995*
- » *Building Regulations 2006*

New South Wales

- » *Environmental Planning and Assessment Act 1979*
- » *Home Building Act 1989*
- » *Fair Trading Act 1987*

Tasmania

- » *Building Act 2000*
- » *Building Regulations 2004*
- » *Plumbing Regulations 2004*
- » *Housing Indemnity Act 1992*

Australian Capital Territory

- » *Construction Occupations (Licensing) Act 2004*
- » *Building Act 2004*
- » *Land (Planning and Environment) Act 1991*

HISTORY OF EDITIONS

History of reviews

This version of the *Guide to Standards and Tolerances* applies to contracts for domestic building work entered into after 1 January 2007.

The *Guide to Standards and Tolerances* dated 2002 (July 2003 in NSW) is applicable to all contracts entered into from 1 July 2002 (July 2003 in NSW) to 31 December 2006.

The *Guide to Standards and Tolerances* dated 1 April 1999 is applicable to contracts entered into from this date to 30 June 2002.

The *Guide to Standards and Tolerances* dated 1 May 1996 is applicable to contracts entered into from this date to 31 March 1999.

The *Guide to Standards and Tolerances* dated December 1992 is applicable to contracts entered into from this date to 30 April 1996.



VICTORIA

Building Commission

Building Advice and
Conciliation Victoria (BACV)
T. 1300 557 559

Complaints –
Advice and Assessment Unit
T. 03 9285 6350

Technical Enquiries
T. 1300 360 380

Building Commission

Level 27, Casselden Place
2 Lonsdale Street
Melbourne VIC 3000

PO Box 536
Melbourne VIC 3001

T. 03 9285 6400
F. 03 9285 6464

www.buildingcommission.com.au

NEW SOUTH WALES

Office of Fair Trading Department of Commerce

Home Building Service
T. 13 32 20

Hearing Impaired TTY
T. 02 9338 4943

Language Assistance
T. 13 14 50

Fair Trading Centre
T. 13 32 20

Office of Fair Trading

1 Fitzwilliam Street
Parramatta NSW 2150

PO Box 972
Parramatta NSW 2124

www.fairtrading.nsw.gov.au

TASMANIA

Building Standards and
Regulation Branch
Workplace Standards Tasmania
Department of Justice
T. 03 6233 7692

Workplace Standards Tasmania

30 Gordons Hill Road
Rosny Park TAS 7018

PO Box 56
Rosny Park TAS 7018

T. 1300 366 322
F. 03 6233 8338

www.wst.tas.gov.au/building

AUSTRALIAN CAPITAL TERRITORY

ACT Planning and Land Authority

16 Challis Street
Dickson ACT 2602
GPO Box 1908
Canberra ACT 2601

T. 02 6207 1923
F. 02 6207 1925

Hearing Impaired TTY
T. 02 6207 2622

www.actpla.act.gov.au